

Owner's Manual

Diesel Generator

MDG75DF4 • MDG100DF4

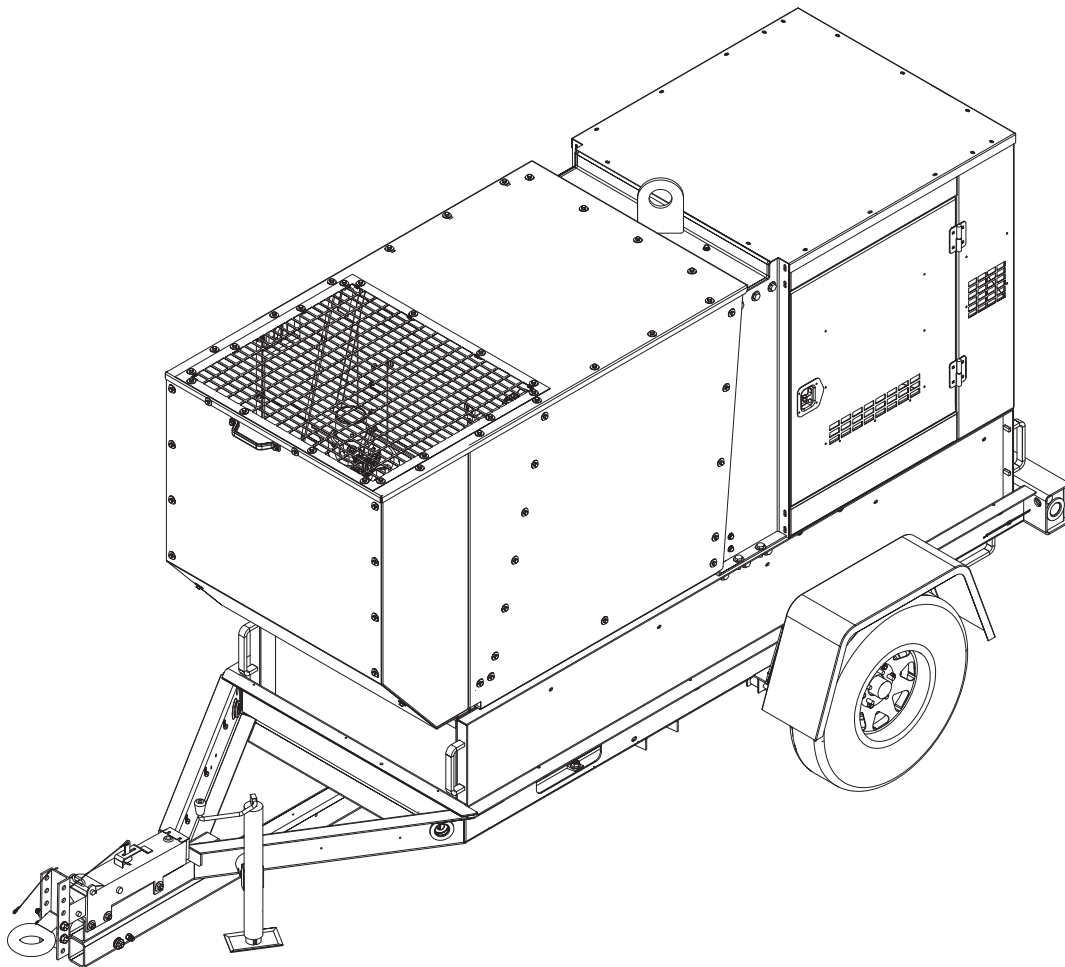

006226

For technical assistance contact:

www.generacmobileproducts.com

Technical Support

1-800-926-9768

SAVE THIS MANUAL FOR FUTURE REFERENCE

Use this page to record important information about your unit.

Unit Model No.	
Unit Serial No.	
Engine Model No.	
Engine Serial No.	
Generator Model No.	
Generator Serial No.	
Date Purchased	

Record the information found on your unit data label on this page. See [Unit and Serial Number Locations](#).

Engine and generator serial numbers are located on separate data plates affixed to the engine and generator respectively.

When contacting a Generac Mobile Authorized Service Dealer (GMASD) about parts and service, always supply the complete model number and serial number of the unit.

Operation and Maintenance: Proper maintenance and care of the unit ensures a minimum number of problems and keeps operating expenses at a minimum. It is the operator's responsibility to perform all safety checks, to verify that all maintenance for safe operation is performed promptly, and to have the equipment checked periodically by a GMASD. Normal maintenance, service and replacement of parts are the responsibility of the owner/operator and, as such, are not considered defects in materials or workmanship within the terms of the warranty. Individual operating habits and usage may contribute to the need for additional maintenance or service.

 **WARNING**

CANCER AND REPRODUCTIVE HARM

www.P65Warnings.ca.gov

(000393a)

 **WARNING**

Breathing diesel engine exhaust exposes you to chemicals known to the State of California to cause cancer and birth defects or other reproductive harm.

- Always start and operate the engine in a well-ventilated area.
- If in an enclosed area, vent the exhaust to the outside.
- Do not modify or tamper with the exhaust system.
- Do not idle the engine except as necessary.

For more information go to

www.P65Warnings.ca.gov/diesel

(000394)

Table of Contents

Section 1: Introduction and Safety

Introduction	1
Read This Manual Thoroughly	1
How to Obtain Service	1
Safety Rules	1
Safety Symbols and Meanings	1
General Hazards	2
Trailer Hazards	2
Electrical Hazards	3
Explosion and Fire Hazards	3
Battery Hazards	4
Fuel Hazards	4
Engine Safety	4
Operating Safety	5
Positioning the Unit	5
Towing Safety	5
Hitch and Coupling	5
Safe Towing Techniques	5
Reporting Trailer Safety Defects	5
Safety and Operating Decals	6

Section 2: General Information

Specifications	11
Unit Dimensions	12
Component Locations	13
Interior and Exterior	13
Control Panel	14
Genset Controller	15
Controller Modes	17
Operator Pages	17
Maintenance Alarms	19
Unit and Serial Number Locations	20
Altitude and Temperature Limitations	20
Diesel Exhaust Fluid (DEF)	20
DEF Specification	20
DEF Warning	20
DEF Storage Guidelines	21
DEF Tank Refilling	21
Selective Catalytic Reduction (SCR) Monitoring	22
Voltage Selector Switch	23
Extended Run Fuel and DEF System (If Equipped)	23

Section 3: Operation

Pre-start Checklist	25
Manually Starting the Unit	25
AUTO (Remote) Starting the Unit	26
Parallel Setup and Operation (If Equipped)	26
Manual Parallel	27
Automatic Parallel	27
Shutting Down the Units in MANUAL Mode	27
Low Idle Switch	27
Wet Stacking	27
Cold Weather Operation	27
Using a Booster Battery or Charger (If Equipped)	28
Generator Output Connections	29
Generator Cam Lock Connections (If Equipped)	29
Using the Voltage Selector Switch	30
Fine Voltage Adjustment	30
Voltage Regulator	30
Customer Convenience Receptacles	30
Main Circuit Breaker	31
DOC and SCR Cleaning Operations	31
Disabling Automatic (AUTO) Exhaust After-Treatment Cleaning	32
Force a Manual Exhaust After-Treatment Cleaning	32
Enable Exhaust After-Treatment Cleaning	32
Transfer Switch	32
Using Extended Run Fuel and DEF System (If Equipped)	33
AUTO Exercise Timer	34
Accessing the Configuration Menu	34
Set the Controller Clock	34
Set the Schedule	34
Setting Up a Daily Scheduled Run	34
Set the Unit to AUTO Mode	34
Shutting Down the Unit	34
Emergency Stop Switch	35
Using the ECU Override Switch	35
Front Hood Operation	35
To Open the Front Hood	35
To Close the Front Hood	36
Towing the Unit	36
Lifting the Unit	37

Section 4: Maintenance

Emissions Information	39
Maintenance	39
Daily Walk Around Inspection	39
Belt Tensioners	39
General Maintenance	39
Engine Oil Recommendations	40
Recommended Oil Types	40
Coolant Recommendation	40
Basic Maintenance Schedule	41
Engine Break-In Requirements	42
Resetting the Maintenance Alarms	42
Testing DEF	42
DEF Tank Cleaning	42
Disposal of DEF	43
Check Generator Drive Plate Torque	43
Jack Maintenance	43
Side-Wind Models	43
Top-Wind Models	43
Trailer Wheel Bearings	43

Section 5: Troubleshooting

General Troubleshooting	45
--------------------------------------	-----------

Section 6: Wiring Diagrams

Wiring Diagrams	47
------------------------------	-----------

Section 1: Introduction and Safety

Introduction

Thank you for purchasing a Generac Mobile product. This unit has been designed to provide high performance, efficient operation, and years of use when maintained properly.

The information in this manual is accurate based on products produced at the time of publication. The manufacturer reserves the right to make technical updates, corrections, and product revisions at any time without notice.

Read This Manual Thoroughly



Consult Manual. Read and understand manual completely before using product. Failure to completely understand manual and product could result in death or serious injury. (000100a)

If any section of this manual is not understood, contact your nearest GMASD, or contact Generac Mobile Technical Service at 1-800-926-9768 or www.generacmobileproducts.com with any questions or concerns.

The owner is responsible for proper maintenance and safe use of the equipment. Comply with regulations the Occupational Safety and Health Administration (OSHA) has established, or with equivalent standards. Also, verify that the unit is applied, used, and maintained in accordance with the manufacturer's instructions and recommendations. Do nothing that might alter safe application/usage and render the unit in noncompliance with the aforementioned codes, standards, laws, and regulations.

Save these instructions for future reference. This manual contains important instructions for the unit that should be followed during setup, operation and maintenance of the unit and battery. ALWAYS supply this manual to any individual who uses this machine.

How to Obtain Service

When the unit requires servicing or repairs, contact a GMASD for assistance. Service technicians are factory-trained and are capable of handling all service needs. For assistance locating a dealer, go to <https://www.generacmobileproducts.com/parts-service/find-service>.

When contacting a GMASD about parts and service, always supply the complete model and serial number of the unit as given on the data decal located on the unit. Record the model and serial numbers in the spaces provided on the front cover of this manual.

Safety Rules

The manufacturer cannot anticipate every possible circumstance that might involve a hazard. The warnings in this manual, and on tags and decals affixed to the unit are, therefore, not all inclusive. If using a procedure, work method or operating technique that the manufacturer does not specifically recommend, verify it is safe for others. Also make sure the procedure, work method or operating technique utilized does not render the equipment unsafe.

Safety Symbols and Meanings

Throughout this publication, and on tags and decals affixed to the unit, DANGER, WARNING, CAUTION and NOTE blocks are used to alert personnel to special instructions about a particular operation that may be hazardous if performed incorrectly or carelessly. Observe them carefully. Their definitions are as follows:



Indicates a hazardous situation which, if not avoided, will result in death or serious injury.

(000001)



Indicates a hazardous situation which, if not avoided, could result in death or serious injury.

(000002)



Indicates a hazardous situation which, if not avoided, could result in minor or moderate injury.

(000003)

NOTE: Notes contain additional information important to a procedure and will be found within the regular text of this manual.

These safety alerts cannot eliminate the hazards that they indicate. Common sense and strict compliance with the special instructions while performing the action or service are essential to preventing accidents.

General Hazards



⚠ DANGER

Asphyxiation. Running engines produce carbon monoxide, a colorless, odorless, poisonous gas. Carbon monoxide, if not avoided, will result in death or serious injury. (000103)



⚠ DANGER

Asphyxiation. Do not operate unit without a properly functioning exhaust system. Doing so will result in death or serious injury. (000340)



⚠ WARNING

Loss of life. This product is not intended to be used in a critical life support application. Failure to adhere to this warning could result in death or serious injury. (000209b)



⚠ WARNING

Hearing Loss. Hearing protection is recommended when using this machine. Failure to wear hearing protection could result in permanent hearing loss. (000107)



⚠ WARNING

Vision loss. Eye protection is required when operating unit. Failure to wear appropriate eye protection could result in vision loss or serious injury. (000407)



⚠ WARNING

Moving Parts. Keep clothing, hair, and appendages away from moving parts. Failure to do so could result in death or serious injury. (000111)



⚠ WARNING

Hot Surfaces. When operating machine, do not touch hot surfaces. Keep machine away from combustibles during use. Hot surfaces could result in severe burns or fire. (000108)

⚠ WARNING

Equipment damage. Do not attempt to start or operate a unit in need of repair or scheduled maintenance. Doing so could result in serious injury, death, or equipment failure or damage. (000291)

⚠ WARNING

Risk of injury. Do not operate or service this machine if not fully alert. Fatigue can impair the ability to service this equipment and could result in death or serious injury. (000215)

⚠ WARNING

Equipment damage. Only qualified service personnel may install, operate, and maintain this equipment. Failure to follow proper installation requirements could result in death, serious injury, and equipment or property damage. (000182a)

⚠ CAUTION

Equipment or property damage. Do not block air intake or restrict proper air flow. Doing so could result in unsafe operation or damage to unit. (000229)

Trailer Hazards

⚠ WARNING

Personal injury. Trailer must be securely coupled to the hitch with the chains correctly attached. Uncoupled or unchained towing could result in death or serious injury. (000233a)

⚠ WARNING

Personal injury. Do not operate unit during transport. Doing so could result in death, serious injury, or property damage. (000231a)

⚠ WARNING

Crushing hazard. Verify unit is properly secured and on level ground. An unsecured unit can suddenly roll or move, causing death or serious injury. (000234a)

⚠ WARNING

Property or Equipment Damage. Tighten wheel lug nuts after first 50 miles to factory specifications. Failure to do so could result in death, serious injury, property or equipment damage. (000235)

Electrical Hazards



⚠ DANGER

Electrocution. In the event of electrical accident, immediately shut power OFF. Use non-conductive implements to free victim from live conductor. Apply first aid and get medical help. Failure to do so will result in death or serious injury. (000145)



⚠ DANGER

Electrocution. Water contact with a power source, if not avoided, will result in death or serious injury.

(000104)



⚠ DANGER

Electrocution. Contact with bare wires, terminals, and connections while generator is running will result in death or serious injury.

(000144)



⚠ DANGER

Electrocution. Verify electrical system is properly grounded before applying power. Failure to do so will result in death or serious injury.

(000152)



⚠ DANGER

Electrocution. Turn utility supply OFF before working on utility connections of the transfer switch. Failure to do so will result in death or serious injury.

(000123)



⚠ DANGER

Electrocution. Never connect this unit to the electrical system of any building unless a licensed electrician has installed an approved transfer switch. Failure to do so will result in death or serious injury.

(000150)



⚠ WARNING

Explosion. Batteries emit explosive gases. Always disconnect negative battery cable first to avoid spark. Failure to do so could result in death or serious injury.

(000238)

Lifting Hazards



⚠ WARNING

Personal injury. Failure to properly connect lifting cables, chains, or straps could result in death, serious injury, or property damage.

(000346)

⚠ WARNING

Personal Injury. Do not use lifting eye if there are signs of damage or corrosion. Doing so could result in death, serious injury, or property damage.

(000433)

⚠ WARNING

Personal Injury. Do not use lifting eye other than as directed. Doing so could result in death, serious injury, or property damage.

(000434)

⚠ WARNING

Personal Injury. Verify all fasteners are properly tightened prior to lifting unit. Failure to do so could result in death, serious injury, or property damage.

(000351)

Explosion and Fire Hazards



⚠ DANGER

Explosion and Fire. Fuel and vapors are extremely flammable and explosive. Add fuel in a well ventilated area. Keep fire and spark away. Failure to do so will result in death or serious injury.

(000105)



⚠ WARNING

Fire risk. Fuel and vapors are extremely flammable. Do not operate indoors. Doing so could result in death, serious injury, or property or equipment damage.

(000281)



⚠ WARNING

Risk of Fire. Unit must be positioned in a manner that prevents combustible material accumulation underneath. Failure to do so could result in death or serious injury.

(000147)

Battery Hazards



⚠ DANGER

Electrocution. Do not wear jewelry while working on this equipment. Doing so will result in death or serious injury.

(000188)



⚠ WARNING

Explosion. Batteries emit explosive gases while charging. Keep fire and spark away. Wear protective gear when working with batteries. Failure to do so could result in death or serious injury.

(000137a)



⚠ WARNING

Explosion. Do not dispose of batteries in a fire. Batteries are explosive. Electrolyte solution can cause burns and blindness. If electrolyte contacts skin or eyes, flush with water and seek immediate medical attention.

(000162)



⚠ WARNING

Risk of burn. Do not open or mutilate batteries. Batteries contain electrolyte solution which can cause burns and blindness. If electrolyte contacts skin or eyes, flush with water and seek immediate medical attention.

(000163a)

⚠ WARNING

Environmental Hazard. Always recycle batteries at an official recycling center in accordance with all local laws and regulations. Failure to do so could result in environmental damage, death, or serious injury.

(000228)

Always recycle batteries in accordance with local laws and regulations. Contact your local solid waste collection site or recycling facility to obtain information on local recycling processes. For more information on battery recycling, visit the Battery Council International website at: <http://batteryCouncil.org>

Fuel Hazards



⚠ DANGER

Explosion and fire. Fuel and vapors are extremely flammable and explosive. No leakage of fuel is permitted. Keep fire and spark away. Failure to do so will result in death or serious injury.

(000192)



⚠ DANGER

Risk of fire. Allow fuel spills to completely dry before starting engine. Failure to do so will result in death or serious injury.

(000174)

- **DO NOT** fill fuel tank near an open flame, while smoking, or while engine is running. **DO NOT** fill tank in an enclosed area with poor ventilation.
- **DO NOT** operate with the fuel tank cap loose or missing.

Engine Safety

Internal combustion engines present special hazards during operation and fueling. Failure to follow the safety guidelines described below could result in severe injury or death. Read and follow all safety alerts described in the engine operator's manual. A copy of this manual was supplied with the unit when it was shipped from the factory.

- **DO NOT** run engine indoors or in an area with poor ventilation. Verify engine exhaust cannot seep into closed rooms or ventilation equipment.
- **DO NOT** clean air filter with gasoline or other types of low flash point solvents.
- **DO NOT** operate the unit without a functional exhaust system.
- Shut the engine down if any of the following conditions exist during operation:
 - Abnormal change in engine speed.
 - Loss of electrical output.
 - Equipment connected to the unit overheats.
 - Sparking occurs.
 - Engine misfires or there is excessive engine/generator vibration.
 - Protective covers are loose or missing.
 - Ambient air temperature is above 120°F (49°C).

Operating Safety

Positioning the Unit



Crushing hazard. Verify unit is properly secured and on level ground. An unsecured unit can suddenly roll or move, causing death or serious injury.

(000234a)

- The area immediately surrounding the unit should be dry, clean, and free of debris.
- If the unit is equipped with a frame grounding stud, follow any local, state, and National Electrical Code (NEC) guidelines when connecting.

Towing Safety

Towing a trailer requires care. Both the trailer and vehicle must be in good condition and securely fastened to each other to reduce the possibility of an accident. Some states require that large trailers be registered and licensed. Contact your local Department of Transportation office to check on license requirements for your particular unit.

Hitch and Coupling

- Verify the hitch and coupling on the towing vehicle are rated equal to, or greater than, the trailer's Gross Vehicle Weight Rating (GVWR).
- Verify the trailer hitch and the coupling are compatible. Verify the coupling is securely fastened to the vehicle.
- **DO NOT** tow trailer using defective parts. Inspect the hitch and coupling for wear or damage.
- Connect safety chains in a crossing pattern under the tongue.
- Before towing the trailer, verify the weight of the trailer is equal across all tires. On trailers with adjustable height hitches, adjust the angle of the trailer tongue to keep the trailer as level as possible.

Safe Towing Techniques

- Practice turning, stopping and backing up in an area away from heavy traffic prior to transporting the unit.
- Maximum recommended speed for highway towing is 45 mph (72 km/h). Recommended off-road towing speed is 10 mph (16 km/h) or less, depending on terrain.
- When towing, maintain extra space between vehicles and avoid soft shoulders, curbs and sudden lane changes.

Reporting Trailer Safety Defects

If you believe your trailer has a defect which could cause a crash or could cause injury or death, you should immediately inform the National Highway Traffic Safety Administration (NHTSA) in addition to notifying Generac Mobile.

If NHTSA receives similar complaints, it may open an investigation; and if it finds that a safety defect exists in a group of vehicles, it may order a recall and remedy campaign. However, NHTSA cannot become involved in an individual problem between you, your GMASD, or Generac Mobile.

To contact NHTSA, you may either call the Auto Safety Hotline toll-free at 1-888-327-4236 (TTY:1-800-424-9153), go to <http://www.safercar.gov>; or write to:

Administrator
NHTSA
1200 New Jersey Avenue S.E.
Washington, DC 20590

You can also obtain other information about motor vehicle safety from <http://www.safercar.gov>.

Safety and Operating Decals

See [Figure 1-1](#) through [Figure 1-4](#). This unit features numerous safety and operating decals. These decals provide important operating instructions and warn of dangers and hazards. The following diagrams illustrate decal locations and descriptions.

Replace any missing or hard-to-read decals and use care when washing or cleaning the unit. Decal part numbers can be found in the parts manual at www.generacmobileproducts.com.

ID	Description	ID	Description
1	Lifting Point	22	Engine Speed Switch
2	Diesel Exhaust Fluid (DEF) Only	23	Notice: Emissions Control Device Equipped
3	Engine Oil Drain	24	Electrical Output
4	Engine Coolant Drain	25	Neutral Bonded to Frame
5	Danger: Electric Shock Hazard	26	Remote Start Terminal Connections
6	Towing Instructions	27	Battery Charger
7	Tie-Down Location	28	Cam Lock Connections
8	Warning: Crushing Hazard	29	Engine Block Heater
9	Ultra Low Sulfur Diesel Fuel Only	30	Connection Terminal Lugs
10	Danger: Diesel Fuel	31	Regeneration Switch
11	Warning: Personal Injury	32	Read and Understand Owner's Manual
12	Electrical Ground	33	Circuit Breaker Switch Operation
13	Fuel Return	34	Operating Instructions
14	Operator's Manual Must Be Stored on Machine	35	Danger: Electrical Backfeed
15	Warning: Personal Injury	36	Relay Labeling
16	Warning: Voltage Selector Switch	37	Electrical Components
17	Warning: Generator Can Automatically Start	38	Fan Clutch
18	Fuel Pickup	39	Fuel Heater
19	Positive Battery Disconnect Switch	40	Voltage Selector Switch - Breaker Reset
20	Control Panel Light Switch (if equipped)	41	Voltage Selector Switch w/600 V Rocker
21	Interior Light Switch (if equipped)	—	—

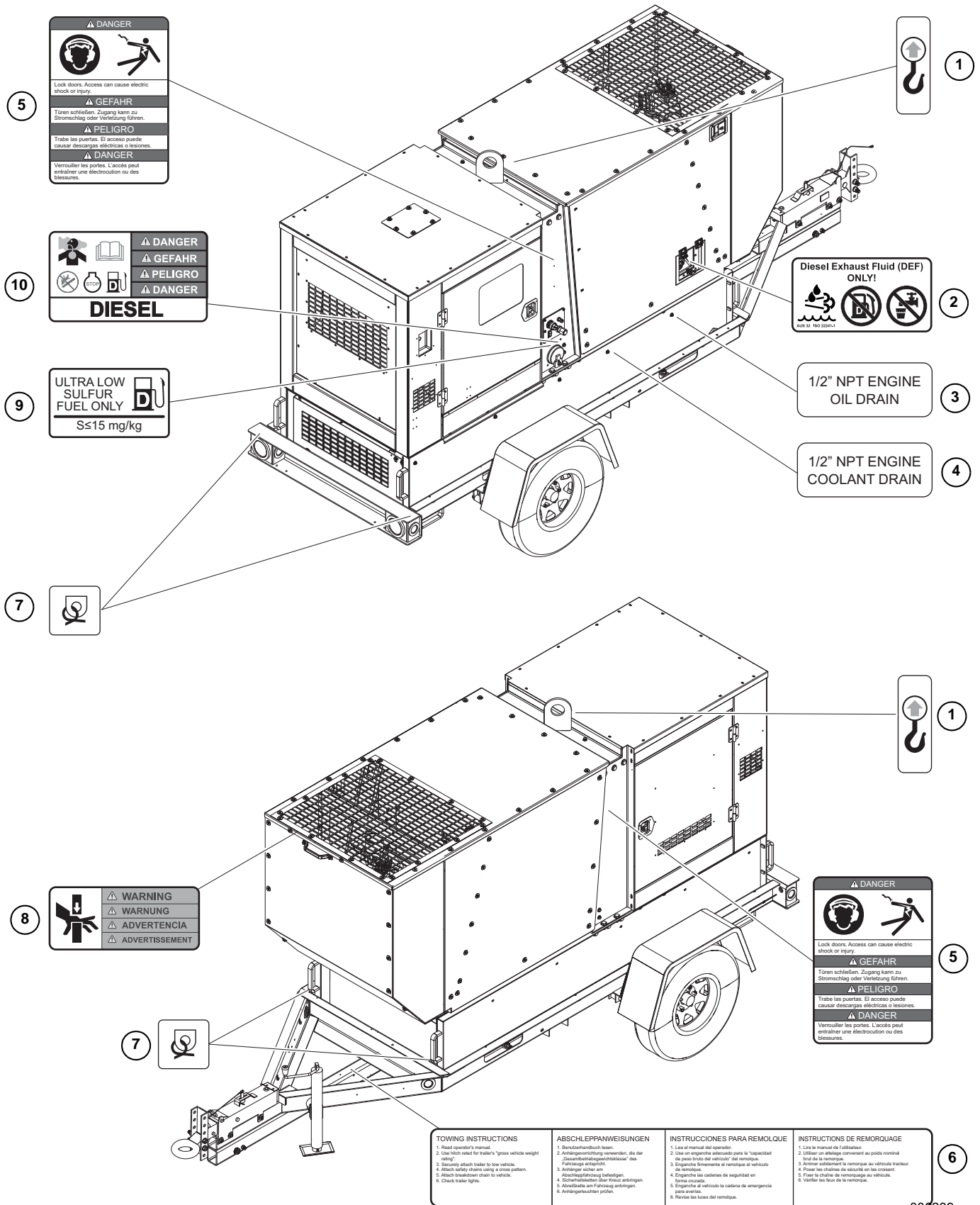
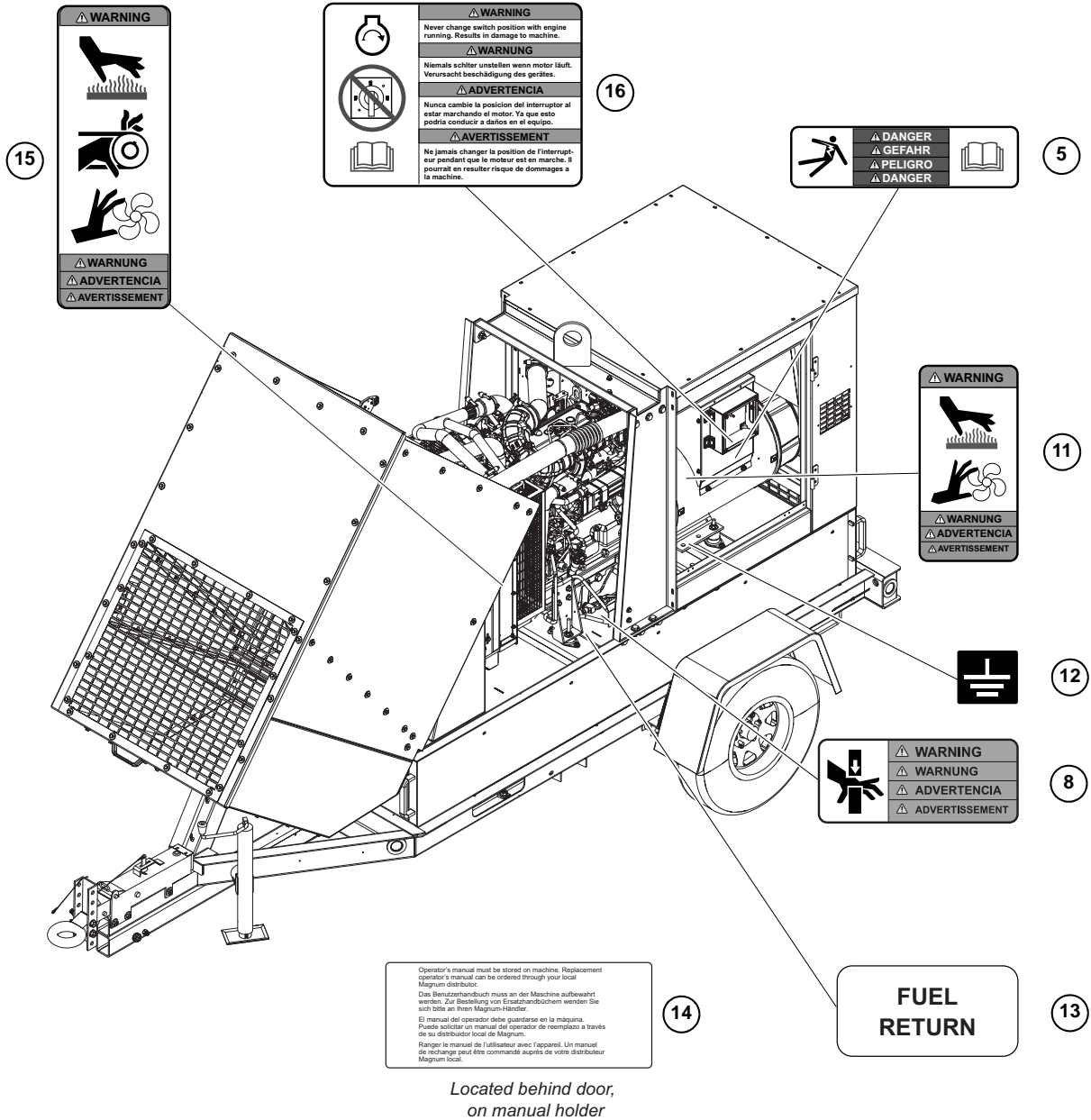

Figure 1-1. Exterior Decals



006240

Figure 1-2. Left Side Interior Decals

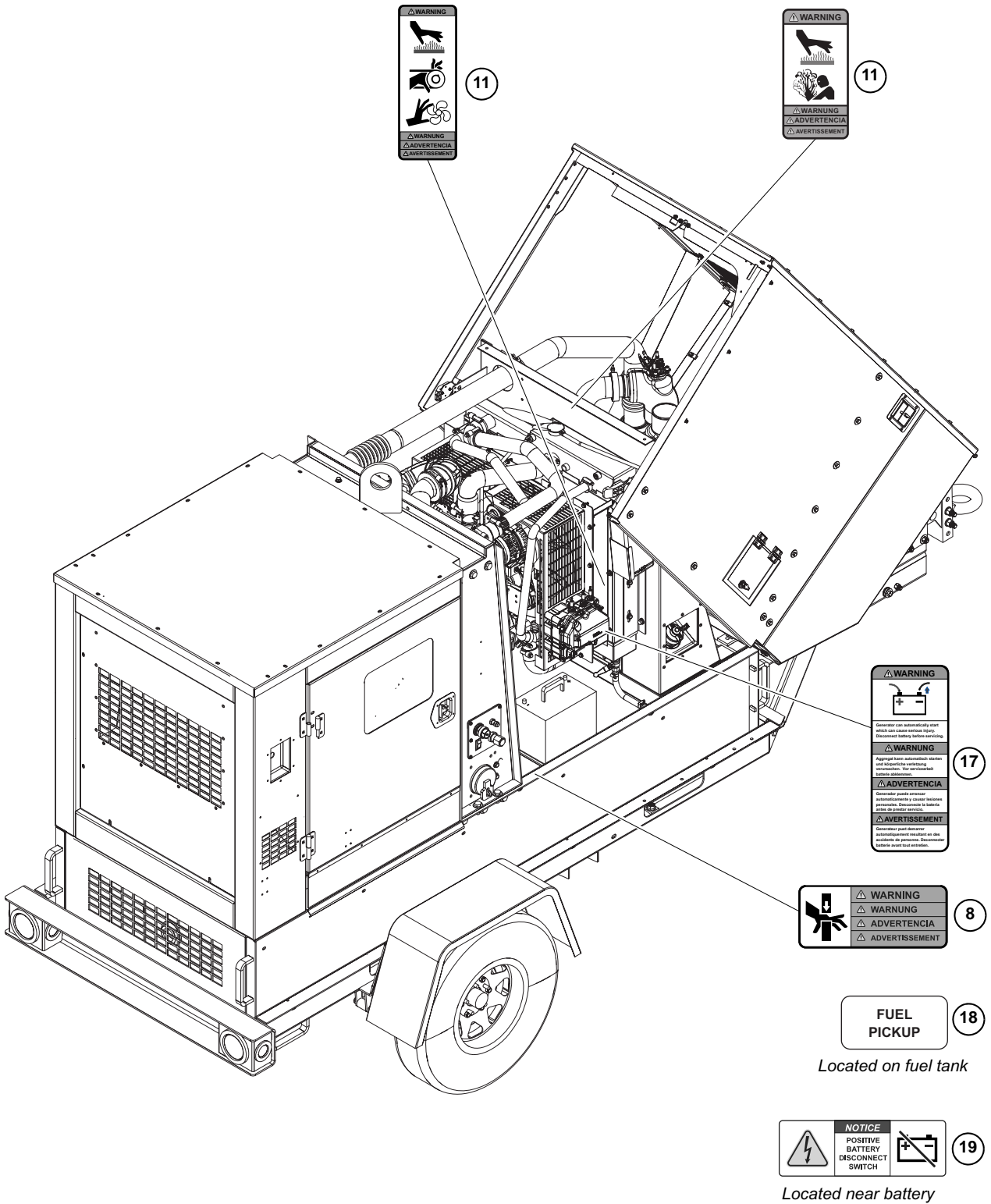

Figure 1-3. Right Side Interior Decals

006241

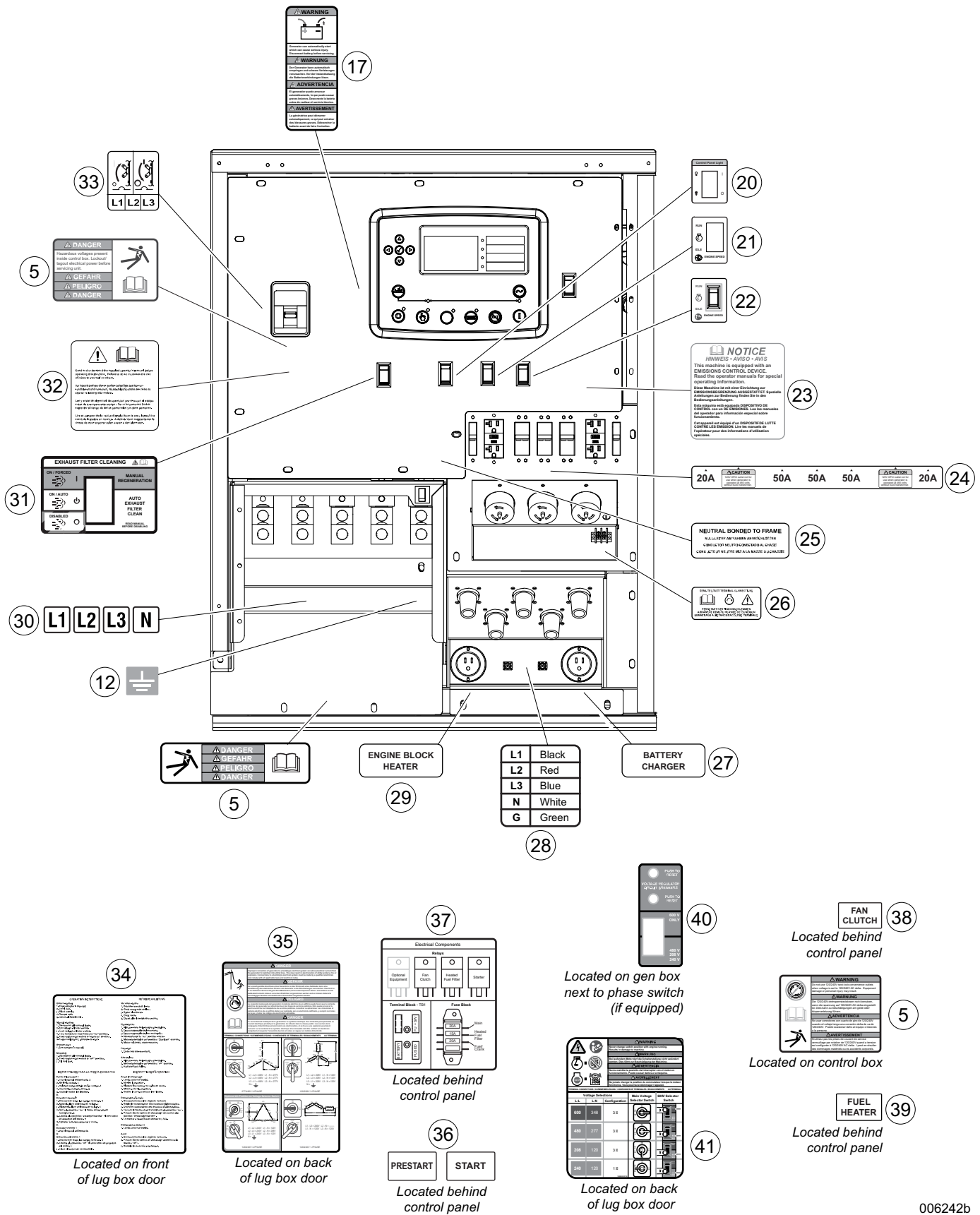

Figure 1-4. Control Panel Decals

006242b

Section 2: General Information

Specifications

Description	Unit of Measure	MDG75DF4	MDG100DF4
Engine			
EPA Tier	—	4	4
Fuel Consumption—100% prime	gph (Lph)	4.85 (18.39)	6.01 (22.72)
Fuel Consumption—75% prime	gph (Lph)	3.74 (14.18)	4.51 (17.07)
Fuel Consumption—50% prime	gph (Lph)	2.63 (9.95)	3.17 (12.02)
DEF Consumption—100% prime	gph (Lph)	0.21 (0.79)	0.26 (0.98)
DEF Consumption—75% prime	gph (Lph)	0.16 (0.60)	0.19 (0.73)
DEF Consumption—50% prime	gph (Lph)	0.12 (0.45)	0.14 (0.52)
Battery—Group Number	—	31	31
Battery—Voltage	VDC	12	12
Battery—Rating	CCA	1,000	1,000
Generator			
Frequency	Hz	60	60
Power Output:			
3Ø Standby	kW (kVA)	68 (85)	85 (106)
480V	A	102	128
208V	A	236	295
3Ø Prime	kW (kVA)	60 (75)	80 (100)
480V	A	90	120
208V	A	208	278
1Ø Standby	kW (kVA)	55 (55)	78 (78)
240V	A	229	325
1Ø Prime	kW (kVA)	55 (55)	78 (78)
240V	A	229	325
Weights			
Dry—Skid Mounted	lb (kg)	3,830 (1,740)	3,980 (1,805)
Operating—Skid Mounted	lb (kg)	4,790 (2,170)	4,530 (2,055)
Dry —Trailer Mounted	lb (kg)	4,440 (2,014)	4,680 (2,122)
Operating—Trailer Mounted	lb (kg)	5,490 (2,490)	5,640 (2,558)
Capacities			
Fuel Tank—Total	gal (L)	165.00 (624.6)	165.00 (624.6)
Fuel Tank—Usable	gal (L)	146.00 (552.7)	146.00 (552.7)
DEF Tank—Total	gal (L)	11.6 (41.6)	11.6 (41.6)
DEF Tank—Usable	gal (L)	9.00 (34.1)	9.00 (34.1)
Coolant—Including Engine	gal (L)	5.5 (21)	5.5 (21)
Oil—Including Filter	gal (L)	3.92 (15.00)	3.92 (15.00)

Description	Unit of Measure	MDG75DF4	MDG100DF4
Maximum Run Time			
24 Hour Tank	hr	30	24
AC Distribution			
Circuit Breaker Size	A	300	400
Trailer			
Hitch—Standard	—	3 in. ring	3 in. ring
Maximum Tire Pressure	psi (kPA)	65 (448)	65 (448)

Specifications are subject to change without notice.

Unit Dimensions

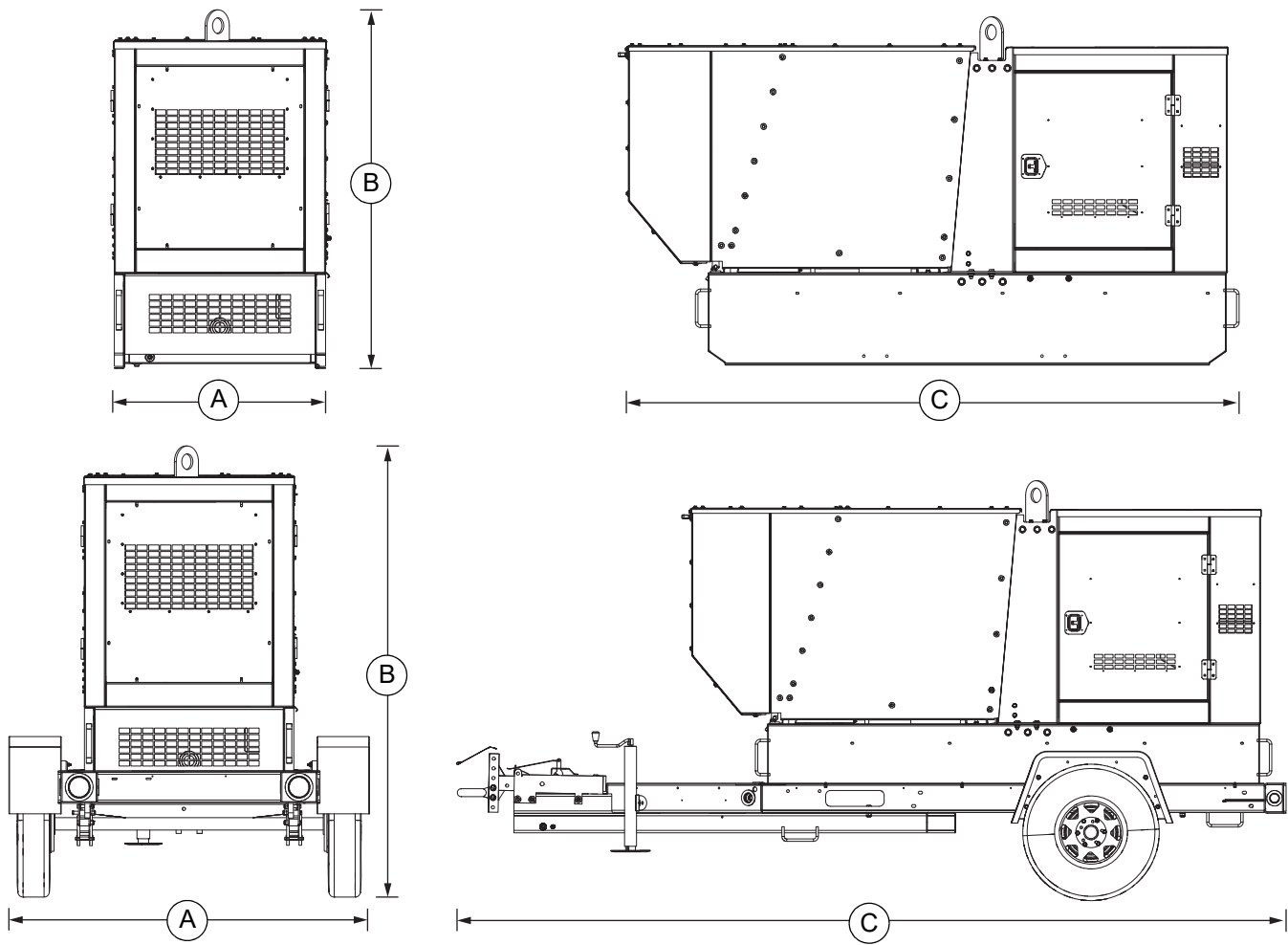

006227

Figure 2-1. Unit Dimensions

	A	B	C
Skid Mounted	40 in (1.02 m)	62 in (1.57 m)	119 in (3.02 m)
Trailer Mounted	69 in (1.75 m)	80 in (2.03 m)	170 in (4.32 m)

Component Locations

Interior and Exterior

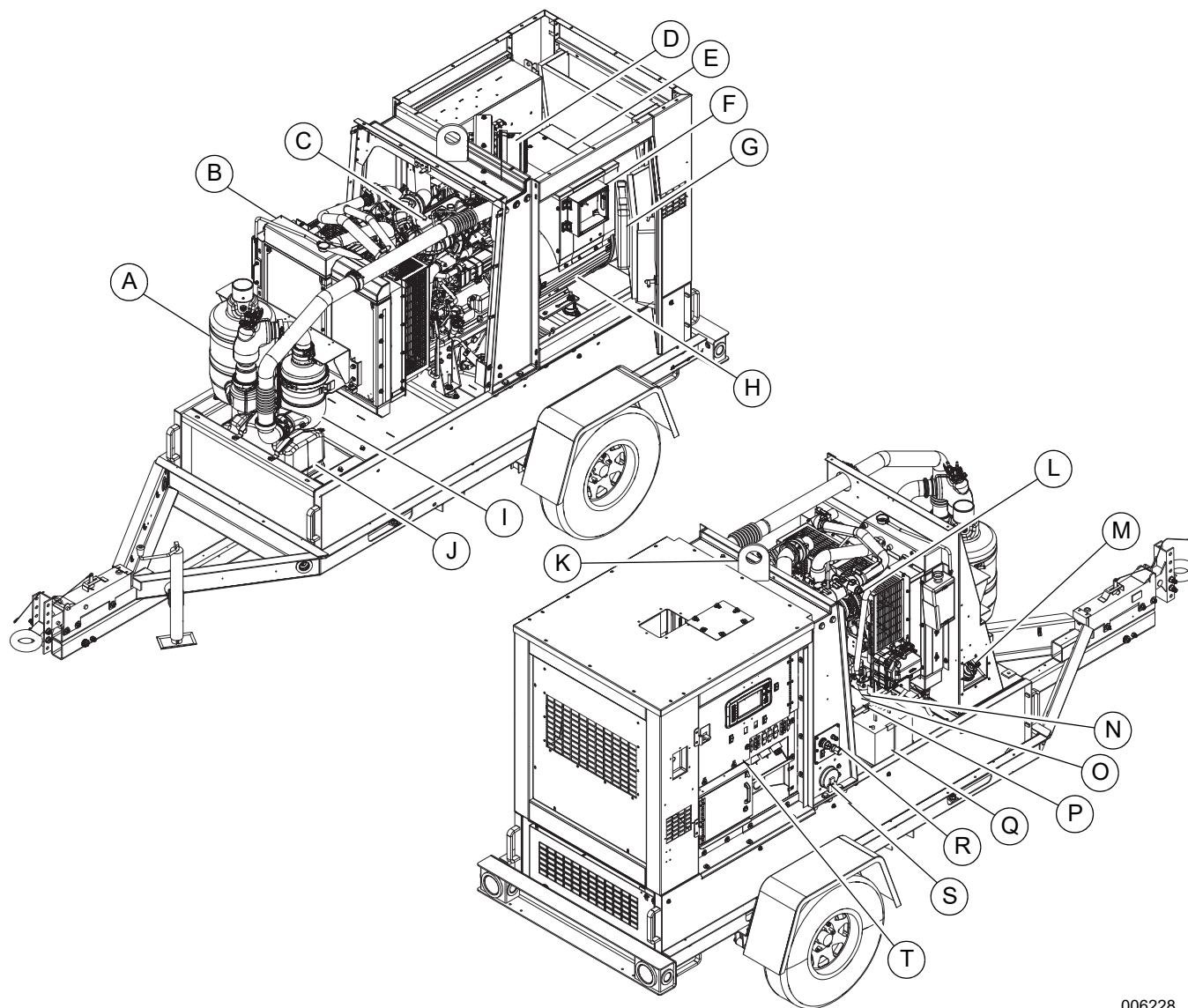

006228

Figure 2-2. Unit Main Components

- | | |
|---|---|
| A Selective catalytic reduction (SCR) module | K Central lift point |
| B Radiator | L Alternator |
| C Engine | M DEF fill |
| D Air filter | N Oil dipstick (behind right-hand lift post) |
| E Generator box | O Fuel filter (behind right-hand lift post) |
| F Voltage selector switch | P Oil filter (behind right-hand lift post) |
| G Manual holder | Q Battery |
| H Generator | R Extended run fuel and DEF system (if equipped) |
| I Diesel oxidation catalyst (DOC) | S Fuel fill |
| J Diesel exhaust fluid (DEF) tank | T Control panel |

Control Panel

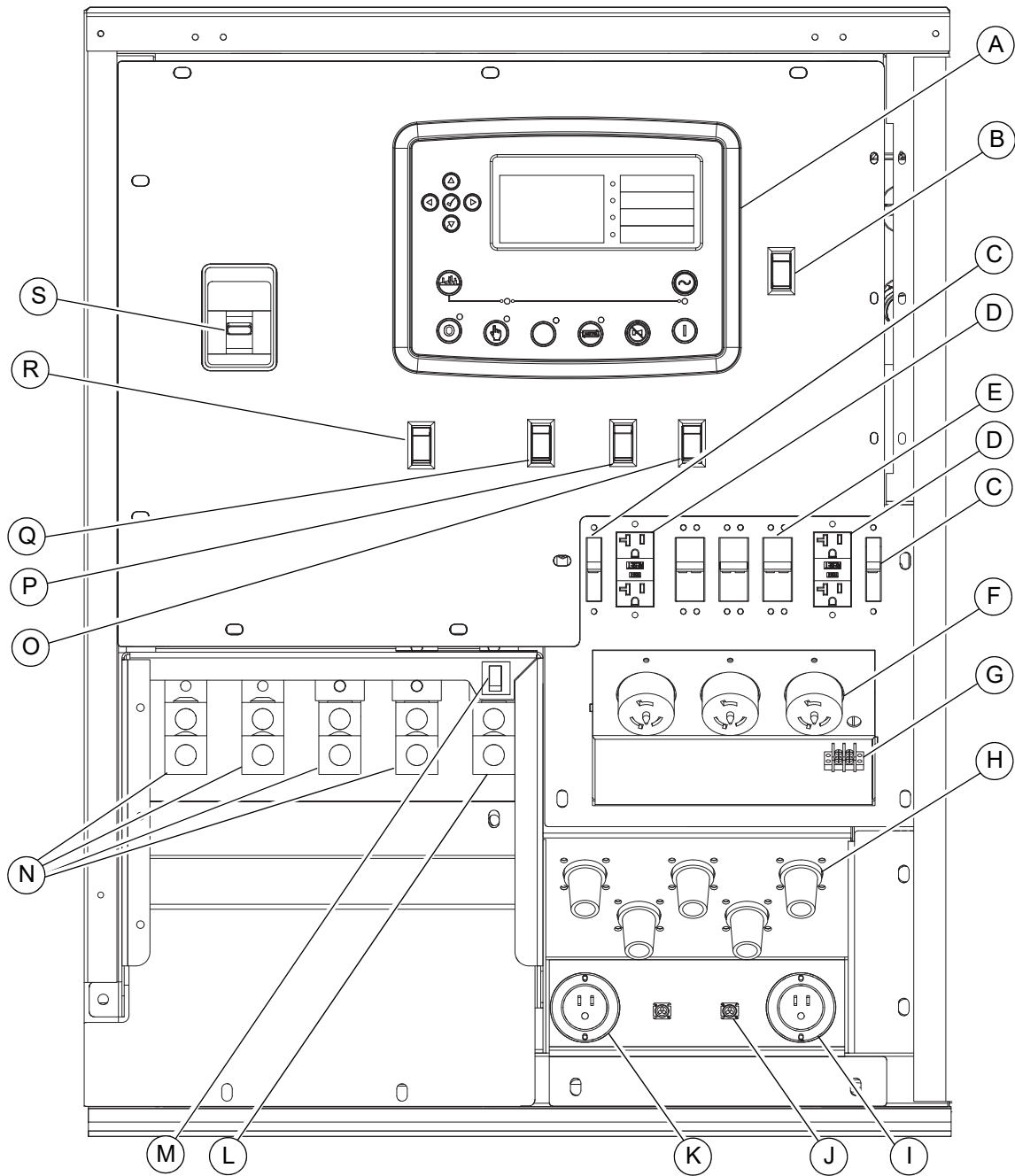

006229b

Figure 2-3. Control Panel Components

- | | |
|--|---|
| A Genset controller | J Paralleling CAN receptacle (2 locations) (if equipped) |
| B Control power switch | K Engine block heater plug (if equipped) |
| C 20A circuit breakers | L Ground lug |
| D 120V GFCI receptacles | M Lug door safety switch |
| E 50A circuit breaker (3 locations) | N Terminal lugs |
| F 120/240V twist-lock receptacle (3 locations) | O Engine speed (RUN-IDLE) switch |
| G Remote start terminal block | P Interior/control panel light switch |
| H Cam lock receptacle (5 locations) (if equipped) | Q Control panel light switch |
| I Battery charger plug (if equipped) | R Exhaust regeneration switch |
| | S Main circuit breaker |

Genset Controller

See [Figure 2-4](#). The genset controller displays real-time operational data, monitors functions of the generator and engine, shuts down the unit for certain fault conditions, displays fault data, and retains up to 250 unit performance events.

The controller is programmable. It can automatically start and stop the genset according to time schedule, fault condition, or load demand.

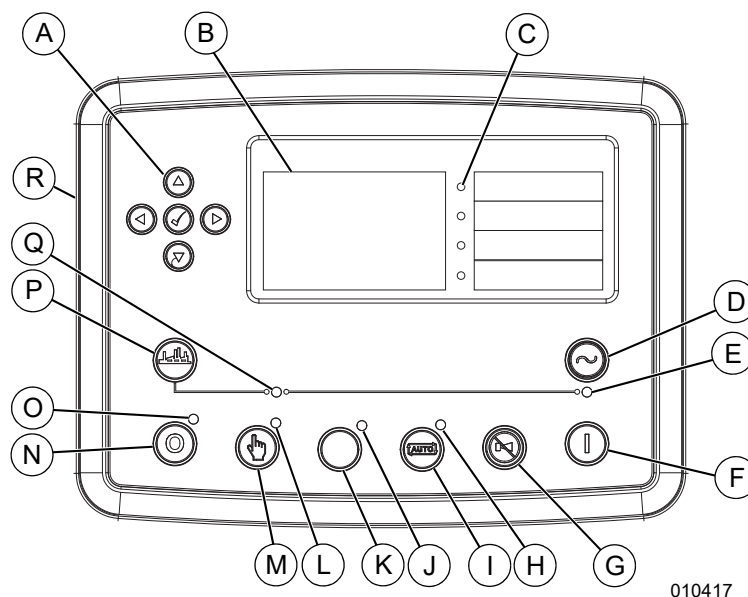

Figure 2-4. Genset Controller

- | | |
|--|--|
| A Navigation buttons | J [not used] |
| B Screen | K [not used] |
| C Indicator LED (4 locations) | L MANUAL Mode LED |
| D Close Generator button | M MANUAL Mode button |
| E Generator Available LED | N Engine STOP/RESET Mode button |
| F Engine START button | O Engine STOP/RESET Mode LED |
| G Alarm Mute and Lamp Test button | P Open Generator button |
| H AUTO Mode LED | Q Open Generator LED |
| I AUTO Mode button | R RS232 serial port (not shown—controller backside) |

(A) Navigation Buttons

See [Figure 2-5](#). Used to navigate the operator pages.

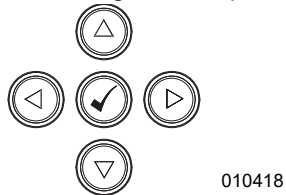

Figure 2-5. Navigation Buttons

Navigate the operator pages as follows.

- ▶ View next
- ◀ View previous
- ▲ Scroll up current
- ▼ Scroll down current
- ✓ Select highlighted item

(B) Controller Screen

The controller screen displays various operational data for unit monitoring, diagnosing, and troubleshooting. See [Operator Pages](#) for more information.

(C) Indicator LEDs

See [Figure 2-6](#). Each LED indicates a condition that impedes normal unit function.

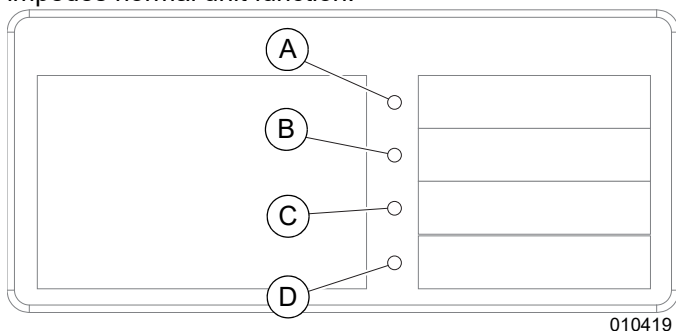

Figure 2-6. Indicator LEDs

If an indicator LED is illuminated, resolve the condition to restore normal unit function, as described in table below.

NOTE: When a condition is resolved, the corresponding indicator LED switches off.

- A *Low Load* indicator LED.
- Indicates genset has operated at less than 30% capacity for more than 15 minutes.
 - Resolve by increasing electrical load. If unable to operate genset at more than 30% load, use a smaller generator.
- B *Lug Door Open* indicator LED.
- Indicates lug-box door is open.
 - Resolve by closing lug-box door. If condition remains unresolved, inspect lug-box door safety switch for proper operation.

C *Emergency Stop* indicator LED.

- Indicates Emergency Stop switch is active (pushed in).
- Resolve by deactivating (pulling out) Emergency Stop switch.

D *Shutdown* indicator LED.

- Indicates a shutdown alarm is present.
- Resolve by resolving shutdown condition.

NOTE: If unable to resolve a condition as recommended, contact a GMASD.

(D) Close Generator Button

Only applies to MANUAL mode.

Closes generator load switch and, when a motorized breaker is in use, closes main breaker. Result is disabling of receptacles, cam locks, and lugs.

NOTE: In units equipped with a manual breaker, limited function is available.

Status is indicated by the Close Generator LED.

(E) Close Generator LED

- When illuminated, receptacles, cam locks, and lugs are disabled
- When not illuminated, receptacles, cam locks, and lugs are enabled

(F) Engine Start Button

When MANUAL mode is active, the Engine Start button begins the start-up sequence.

The Engine Start button does not begin the start-up sequence when:

- A shutdown alarm is active.
- The controller is in AUTO or STOP mode.

NOTE: In AUTO or STOP mode, the Engine Start button activates the ECM.

(G) Alarm Mute and Lamp Test Button

The Alarm Mute and Lamp Test button stops the audible alarm and illuminates functional controller LEDs.

To test the LEDs, press and hold button. All LEDs illuminate. When button is released, the LEDs switch off.

NOTE: If an LED does not illuminate when button is pushed, the LED is non-functional.

(H) AUTO Mode LED

- When illuminated, AUTO mode is active.
- When not illuminated, AUTO mode is not active.

(I) AUTO Mode Button

Switches the mode to AUTO. See [Controller Modes](#) for important guidelines.

Status is indicated by the AUTO Mode LED.

(J) [not used]

This button is inactive.

(K) [not used]

This LED is inactive.

(L) MANUAL Mode LED

- When illuminated, MANUAL mode is active.
- When not illuminated, MANUAL mode is not active.

(M) MANUAL Mode Button

Switches the mode to MANUAL. See [Controller Modes](#) for important guidelines.

Status is indicated by the MANUAL Mode LED.

(N) Engine STOP/RESET Mode Button

Switches the mode to STOP. See [Controller Modes](#) for important guidelines.

Status is indicated by the STOP/RESET Mode LED.

(O) Engine STOP/RESET Mode LED

- When illuminated STOP mode is active.
- When not illuminated, STOP mode is not active.

(P) Open Generator Button

Only applies to MANUAL mode.

Opens the generator load switch and, when a motorized breaker is in use. Result is enabling of receptacles, cam locks, and lugs.

NOTE: In units equipped with a manual breaker, limited function is available.

Status is indicated by the Open Generator LED.

(Q) Open Generator LED

- When illuminated, receptacles, cam locks, and lugs are enabled.
- When not illuminated, receptacles, cm locks, and lugs are disabled.

Controller Modes**MANUAL Mode**

MANUAL mode is distinguished by full operator control of unit start-up and shut-down functions, and by full operator control of generator load and unload functions.

AUTO Mode

AUTO mode is distinguished by automation of unit start-up and shut-down functions, and by automation of generator load and unload functions.

AUTO mode utilizes the remote start connections. For remote starting procedures, see [Section 3, Operation](#).

AUTO mode utilizes a programmed schedule, which can

be modified.

NOTE: To modify the AUTO mode programmed schedule, use the Deep Sea Configuration Suite software.

STOP Mode

STOP mode is distinguished by the following:

- Unloads the generator.
- Clears active alarms—if alarm conditions have been resolved.
- Shuts down the unit.
- Deactivates the Engine Start button.
- Stops all AUTO mode automation (if applicable).
- Controller power remain ON.

Switching Mode

1. Verify controller is ON.

NOTE: The engine can be running but it is not required.

2. Stop drawing power from the unit: Stop using equipment plugged into receptacles, cam locks, and anything connected to the lugs.
3. See [Figure 2-4](#). Press the desired *Mode* button. The unit immediately changes to the selected mode.

Operator Pages

Operator pages contain various data for unit monitoring, diagnosing, and troubleshooting. The pages are:

- Status page
- Engine page
- Generator page
- Alarm page
- ECU DTC page
- Event Log page
- Serial Port page
- Program File Information page
- About page

NOTE: Operator pages are available after normal unit start-up.

NOTE: Operator pages are view-only. No settings can be added, modified, or deleted.

Generator Page

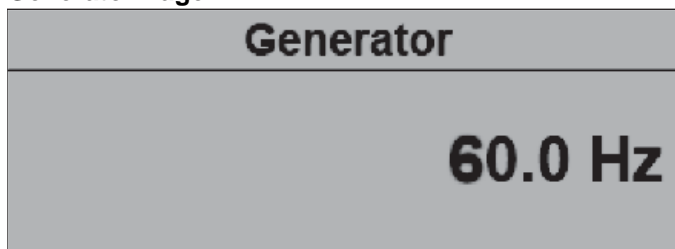

010422

Figure 2-7. Generator Page

The Generator page displays the following generator data, in real time (press ▲ or ▼ to scroll).

- Voltage (ph-N)
- Voltage (ph-ph)
- Frequency
- Current (A)
- Load ph-N (kW)
- Total load (kW)
- Load ph-N (kVA)
- Total load (kVA)
- Single phase power factors
- Power factor average
- Load ph-N (kvar)
- Total load (kvar)
- Accumulated load (kWh, kVAh, kvarh)
- Loading scheme
- Phase rotation
- Nominal
- Active configuration

NOTE: The list above varies, according to generator make, model, and features.

NOTE: As possible, distribute electrical loads equally among generator lines. Minor load imbalances (10% or less) usually do not cause problems. When loading generator, observe the load (amperage) on each line.

Alarms Page

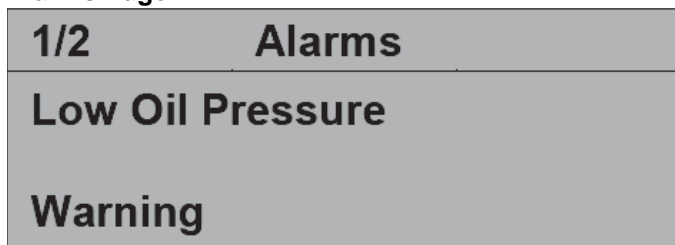

010423

Figure 2-8. Alarm Page

The Alarms page displays active warnings and active alarms, including engine DTCs.

ECU DTC Page

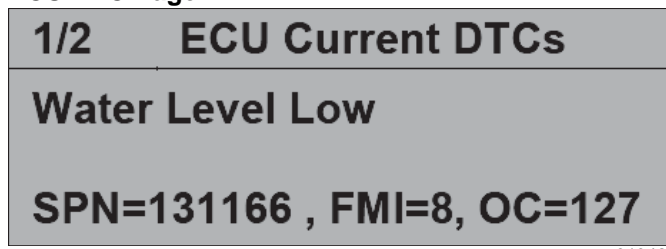

010424

Figure 2-9. ECU DTC Page—Current DTCs

The ECU Current DTC page displays active ECU DTCs. Press ► to view previous ECU DTCs.

NOTE: See engine manual for information on ECM DTCs.

NOTE: All DTCs display on the ECU DTC page. Some DTCs may also display in the Event Log, with similar descriptions as those displayed on the ECU DTC page.

Event Log Page

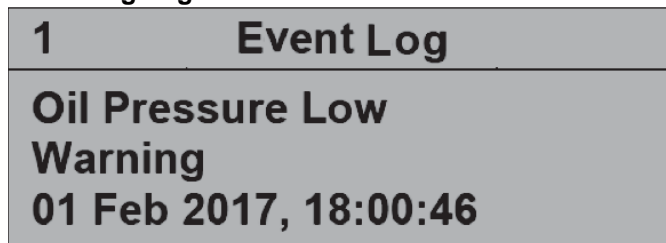

010425

Figure 2-10. Event Log Page

The Event Log page displays current and previous alarms.

- Event Log capacity is 250 alarm events. After 250 events are logged, each new event overwrites the oldest.
- Only alarms are logged.
- Newest event displays at top of log; oldest at bottom.

Serial Port Page

The Serial Port page displays information about the RS232 serial port, which enables data transfers. If an external modem is connected to the serial port, modem information also displays.

NOTE: The Serial Port page display may vary, in accordance with controller configuration.

See [Figure 2-11](#). If a modem is connected to the controller, *Modem* displays, as illustrated.

Serial Port	
Baud	9600
SlaveID	10
	Modem

010426

Figure 2-11. Serial Port Page. If modem is not connected, RS232 displays in place of Modem.

See [Figure 2-12](#). When the controller can accept a data transfer, *Modem Ready* displays, as illustrated.

Serial Port	
	Orange Modem Ready

010427

Figure 2-12. Serial Port Page—Modem Ready

Program File Information Page

PROGRAM FILE INFORMATION
MDG25IF4 Mobile Generator
PRGMD CNTLR MDG25 NP 24
A0000xxxxxx.dse Revision A

010428

Figure 2-13. Program File Information Page

The Program File Information page displays the following controller information.

- Controller model unit
- Program file name
- Program PN
- Program version

About Page

About	
Variant	7310
Application	V5.0.23
USB ID	6B248D0576

About	
Bootloader	V3.2.1
Analogue	V1.2.0

About	
Engine Type	Isuzu 4L
Version	V1.18.0

010429

Figure 2-14. About Page

The About page displays various general information about the unit and controller, as illustrated.

Maintenance Alarms

Maintenance alarms indicate a regular-maintenance service interval is expired. To resolve the condition, perform the indicated service, then re-set the corresponding service interval.

To re-set a service interval:

1. Display the Engine page.
2. Scroll (▲ or ▼) until the appropriate service interval is highlighted.

NOTE: The expired interval displays on the Alarm page.

3. Press and hold the Engine STOP/RESET Mode button until **###* hr service** changes to **0 hr service**.

**A number displays. The value varies according to what service interval is highlighted.*

Unit and Serial Number Locations

See **Figure 2-15** to locate the unit ID tag (A) and vehicle identification number (VIN) tag (B). Important information such as the unit model number, serial number, VIN, and tire loading information are listed on these tags. Record the information from these tags in the event the tags are lost or damaged. This information may be needed when ordering parts or requesting assistance.

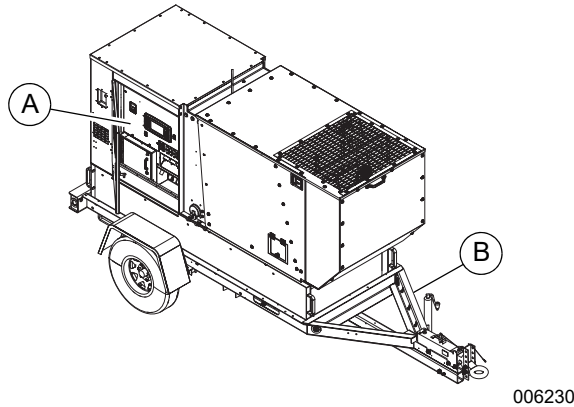

Figure 2-15. Unit and Serial Number Locations

Altitude and Temperature Limitations

All units are subject to derating for altitude and temperature. Derating reduces the available power for operating tools and accessories connected to the outlets.

The unit provides full prime power up to an altitude of 13,100 ft (3,993 m). The maximum air temperature at which the unit can provide full prime power is defined in the table below. If the unit is operated beyond this limit at full power, the coolant temperature will exceed the maximum allowable limit of 235 °F (113 °C) and cause the engine to shut down.

Model	Altitude Limit: ft (m)		Air Temp. Limit: °F (°C)
	Prime	Standby	
MDG75	13,100 (3,993)	10,800 (3,292)	120 (49)
MDG100	13,100 (3,993)	10,800 (3,292)	120 (49)

Diesel Exhaust Fluid (DEF)

NOTE: Unit does not ship from factory with DEF in tank.

DEF Specification



Equipment damage. Do not alter DEF. Use approved DEF only. Failure to do so could cause equipment damage.

(000337)

Diesel exhaust fluid (DEF) is a high purity liquid that is injected into the exhaust system of SCR engines. Maintaining the purity of DEF is important to avoiding malfunctions in the SCR system. Engines requiring DEF shall use a quality product that meets the requirements for Aqueous Urea Solution 32 (AUS 32) according to ISO 22241-1. The use of John Deere DEF is recommended.

If John Deere DEF is not available, use DEF certified by the American Petroleum Institute (API) Diesel Exhaust Fluid Certification Program, or by the AdBlue™ Diesel Exhaust Fluid Certification program. Look for the API certification symbol or the AdBlue name on the container.

NOTE: Do not create DEF by mixing agricultural grade urea with water. Do not use additives, as this can damage the after treatment system.

DEF Warning

DEF can be corrosive to material such as steel, iron, zinc, nickel, copper, aluminum, and magnesium. The recommended material for transport and storage of DEF is made of polyethylene, polypropylene, or stainless steel. These are not all-inclusive lists. For additional information, see ISO 22241 or contact a DEF supplier.

DEF Storage Guidelines

WARNING

Risk of poisoning. Do not ingest diesel exhaust fluid. Seek medical attention immediately if consumed. Failure to do so could result in serious injury.

(000334)

WARNING

Personal injury. Do not inhale diesel exhaust fluid fumes. If breathing becomes difficult, move to an area with fresh air and seek medical attention immediately. Failure to do so could result in serious injury.

(000335a)

WARNING

Personal injury. Avoid contact with eyes. Flush eyes thoroughly with water and seek medical attention immediately. Failure to do so could result in serious injury.

(000336)

NOTE: Reference the Materials Safety Data Sheet (MSDS) for additional information.

DEF freezes at temperatures below 12°F (-11°C). Do not use additives to reduce the freezing temperature. Additives currently available are more corrosive than DEF, and will cause component and system degradation and negatively impact reliability. For more information, see the operator manual, or contact a DEF supplier.

DEF quality degrades rapidly at temperatures above 140°F (60°C). To maintain emissions compliance, the urea concentration must remain between 31.8–33.2%.

Ideal conditions for storage of DEF are:

- Store at temperatures between 23–86°F (-5–30°C)
- Store in sealed dedicated containers to avoid contamination and evaporation

Under these conditions, DEF is expected to remain usable for a minimum of 18 months. Storing DEF at higher temperatures can reduce its useful life by approximately six months for every 9°F (5°C) above 86°F (30°C). Long-term storage in the DEF tank (over 12 months) is not recommended. If long-term storage is necessary, test DEF prior to operating engine. See [Testing DEF](#).

DEF Tank Refilling

WARNING

Personal injury. Avoid prolonged contact with skin. Wash skin thoroughly with soap and water. Remove contaminated clothing and wash before reuse. Seek medical attention if skin becomes irritated. Failure to do so could result in personal injury.

(000338a)

CAUTION

Equipment Damage. Immediately clean any surfaces with water that come in contact with diesel exhaust fluid. Failure to do so could result in equipment damage.

(000365)

IMPORTANT NOTE: If DEF is filled into engine fuel tank or other fluid compartment, do not operate engine until system is properly purged of DEF. Contact your John Deere dealer immediately to determine how to clean and purge the system.

NOTE: Use only distilled water to rinse components that are used to deliver DEF. Tap water can contaminate DEF. If distilled water is not available, rinse with clean tap water, then thoroughly rinse with ample amounts of DEF.

Reasonable care should be taken when refilling the DEF tank. Verify the DEF tank cap area is free of debris before removing the cap. Wipe clean with a lint free cloth to remove debris from tank cap. Seal DEF containers between use to prevent contamination and evaporation. Avoid splashing DEF, and do not allow DEF to come into contact with skin, eyes, or mouth.

DEF can be corrosive to materials such as steel, iron, zinc, nickel, copper, aluminum, and magnesium. Use suitable containers to transport and store DEF. Containers made of polyethylene, polypropylene, or stainless steel are recommended.

NOTE: Keep anything used to store or dispense DEF clean of dirt and dust. Wash and rinse containers or funnels thoroughly with distilled water to remove contaminants.

If an unapproved fluid, such as diesel fluid or coolant is added to the DEF tank, **contact your John Deere dealer immediately** to determine how to clean and purge the system.

If water has been added to the DEF tank, a tank cleaning is necessary. After refilling the tank, check the DEF concentration. See [Testing DEF](#). The operator must maintain appropriate DEF levels at all times. Check the DEF level daily and refill the tank as needed. The filling port is identified by a blue colored cap embossed with the DEF symbol.

Selective Catalytic Reduction (SCR) Monitoring

This unit is equipped with a selective catalytic reduction (SCR) system to meet Tier 4 EPA emissions standards. This section gives an explanation of the indicators that are displayed on the SCR status page of the engine tab.

To access the SCR status page, press any direction button (▲, ►, ▼, ◀) to enter the maintenance screens, and when on the engine tab, press the ▼ button to toggle through the pages until the SCR status page appears. There are four areas on the SCR status page that communicate various information to the operator. The areas and the indicators that appear in those areas are explained here:

- HEST Lamp (High Exhaust System Temperature):** This area displays the regeneration underway indicator above the words HEST LAMP - SOLID when the unit is in the process of the exhaust catalyst. During the regeneration process, the exhaust temperature will be very high.
- SCR Lamp:** This area displays the regeneration indicator above the words SCR LAMP - SOLID when auto exhaust filter cleaning is enabled. When the unit is being operated with auto exhaust filter cleaning disabled, the indicator will begin to flash above the words SCR LAMP - FLASHING if the soot load level goes above 80%.

- SCR Inhib:** This area displays the disabled regeneration indicator above the words SCR INHIB - SOLID when auto exhaust filter cleaning is disabled.
- Alarm:** This area will display the engine alarm indicator above the words ALARM - SOLID when an alarm condition occurs. This area displays different text depending upon which alarm condition occurs.

See [DOC and SCR Cleaning Operations](#) for more information on the operation of auto exhaust filter regeneration and service regeneration.

DPF Regeneration Lamps

Depending upon the Engine Type selected in the module's configuration, the Engine section may include the DPF Regeneration Lamps page. This page contains icons (see [Figure 2-16](#)) to show the status of various ECU functions, some of which are applicable to Tier 4 engine requirements. The icons flash at different rates to show the status of the ECU function, refer to the engine manufacturer for more information about this.

Icon	Fault	Description
	ECU Amber Alarm	The module received an Amber fault condition from the engine ECU.
	ECU Red Alarm	The module received a Red fault condition from the engine ECU.
	DPF Active	The module received a fault indication from the engine ECU informing that the Diesel Particulate Filter is active.
	DPF Inhibited	The module received a fault indication from the engine ECU informing that the Diesel Particulate Filter has been inhibited.
	DPF Stop	The module received a fault indication from the engine ECU informing that the Diesel Particulate Filter has been stopped.
	DPF Warning	The module received a fault condition from the engine ECU informing that the Diesel Particulate Filter has a fault condition.
	HEST Active	The module received a fault indication from the engine ECU informing that the High Exhaust System Temperature is active.
	DEF Low Level	The module received a fault condition from the engine ECU informing that the Diesel Exhaust Fluid Low Level is active.
	SCR Inducement	The module received a fault indication from the engine ECU informing that the Selective Catalytic Reduction Inducement is active.

Example:

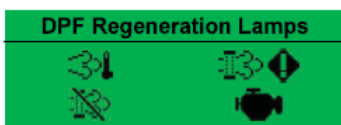

Figure 2-16. DPF Regeneration Lamps

Voltage Selector Switch

**WARNING**

Electric Shock. Never change the voltage selector switch while the engine is running or the controller is on. Doing so could result in death, serious injury or equipment damage.

(000302)

The voltage selector switch mechanically configures the main windings of the generator to provide a Hi Wye, Low Wye, Zig Zag or Delta configuration providing single and three phase voltage output to the main breaker. Voltage ranges are selected by rotating the handle on the switch to the desired voltage.

The voltage selector switch is equipped with a lockout mechanism to prevent unauthorized changing of the voltage setting by locking the handle in place.

See [Using the Voltage Selector Switch](#) for instructions on switching the voltage.

Extended Run Fuel and DEF System (If Equipped)

See [Figure 2-2](#). The Extended Run Fuel and DEF System is a means to connect external diesel fuel and DEF tanks to the unit on-board tanks. When external tanks are connected, the generator continuously runs in excess of 24 hours.

NOTE: Capacity of the external tanks determines additional run-time.

When connected, the Extended Run Fuel and DEF System uses the controller to monitor the level of the onboard tanks to determine when to automatically refill each with either diesel fuel or DEF. When the tank levels drop to a predetermined set point, power is supplied to refill the tanks. Once the tank has filled and has reached the upper level set point, power to the pumps is removed and the system stops refilling. This cycle will repeat automatically for all subsequent low-level occurrences.

For more information, see [Using Extended Run Fuel and DEF System \(If Equipped\)](#).

This page intentionally left blank.

Section 3: Operation

Pre-start Checklist

All items in the pre-start checklist must be completed before starting the unit. This checklist applies to both manual and remote starting of the unit.



⚠️ WARNING

Consult Manual. Read and understand manual completely before using product. Failure to completely understand manual and product could result in death or serious injury. (000100a)

⚠️ WARNING

Equipment damage. Do not attempt to start or operate a unit in need of repair or scheduled maintenance. Doing so could result in serious injury, death, or equipment failure or damage. (000291)



⚠️ WARNING

Risk of Fire. Unit must be positioned in a manner that prevents combustible material accumulation underneath. Failure to do so could result in death or serious injury. (000147)

- Verify all maintenance procedures are up to date. For more information, see [General Maintenance](#) and [Basic Maintenance Schedule](#).
- Verify the unit is level.
- Verify there is no water inside, on, or near the unit; dry if needed.
- For grounding requirements, follow any local, state, or National Electrical Code (NEC) guidelines.
- Verify the control power switch is OFF (O).
- Verify all circuit breakers are OFF (O).
- Inspect all electrical cords; repair or replace any that are cut, worn, or bare.
- Verify oil, coolant, and fuel levels are correct, per the engine manufacturer's manual.
- Verify battery connections are secure.
- Turn the battery disconnect switch ON (if equipped).
- Verify engine fan belt tension and condition are within spec.
- Verify engine fan belt guard is installed and secure.
- Check engine exhaust system for loose or rusted components.
- Verify the radiator and surrounding shroud are clear of debris.
- Verify all covers are in place and secure.

- Verify all electrical connections at the connection lugs, if equipped, are tight and wired correctly.
- Verify the voltage selector switch is set to the desired voltage and locked.
- Verify the emergency stop switch is pulled out.

Manually Starting the Unit



⚠️ DANGER

Asphyxiation. Running engines produce carbon monoxide, a colorless, odorless, poisonous gas. Carbon monoxide, if not avoided, will result in death or serious injury. (000103)



⚠️ WARNING

Fire risk. Fuel and vapors are extremely flammable. Do not operate indoors. Doing so could result in death, serious injury, or property or equipment damage. (000281)

Operating the unit in MANUAL mode allows the operator to start and stop the unit from the controller using the engine START and STOP buttons.

To start unit in MANUAL mode:

1. Set controller power to ON (I). The controller begins its boot sequence. When controller is ready, the Home page displays.

NOTE: The controller boots in STOP mode, as indicated at the top of the screen.

NOTE: If starting the unit in cold ambient temperatures, it is recommended to start the unit at low idle, and allow the engine to heat up the lubricating oil. For more information, see [Low Idle Switch](#).

NOTE: The controller can be started from any screen when it is in MANUAL mode.

2. Press engine START (I) button. The controller begins the engine startup sequence and starts the engine—provided no engine faults prevent starting.

NOTE: It takes several seconds for the engine to warm (run smoothly and reach its operating speed). During warming, the screen displays a different voltage than the voltage selector switch.

3. If the engine does not start within three crank attempts, the controller will display the failed start alarm. The starting sequence can be repeated after the starter has had a minimum of two minutes to cool. Pressing the ENTER (✓) button will clear the alarm and reset the controller.

NOTE: Engine preheat is controlled by the ECU.

- When the engine starts, it accelerates to operating speed. If the Low Speed Idle switch is ON, the engine accelerates to the low idle speed set-point.

IMPORTANT NOTE: Allow the engine to warm for approximately 10 minutes. Failure to properly warm the engine prior to loading can cause premature engine wear or failure.

- When engine is warm, turn OFF the Low Idle Speed switch.
- Check the generator for excessive noise or vibration and any coolant, oil, or fuel leaks before applying any loads.
- Verify the AC output voltage is correct. See [Fine Voltage Adjustment](#).
- Verify generator frequency (Hz) is correct on the generator screen. The frequency should be the rating specified on the unit data tag.
- If all wiring connections have been made correctly, switch the main circuit breaker to ON (I), and then add any loads attached to the receptacles by switching the respective circuit breaker to the ON (I) position. A slight change in engine sound when a load is applied to the unit is normal.

AUTO (Remote) Starting the Unit

AUTO mode allows the operator to start and stop the unit by closing the remote start contacts (on the lug panel), programming a schedule stop sequence in the controller, or through a telemetry signal (if equipped).

NOTE: When in AUTO mode, the STOP button can be pressed to stop the unit.

Review the [Pre-start Checklist](#) and [Manually Starting the Unit](#) before putting the unit in AUTO mode. Follow all safety warnings and review all information on isolating the generator with a transfer switch if the unit is to be used as a standby power supply. See [AUTO Exercise Timer](#), then proceed as follows:

- Perform a manual start of the unit at least once to verify the engine and generator are operating correctly.
- To check the remote start circuit, remove the wires from the remote start terminal block. Press the AUTO button, and the display screen will show auto mode at the bottom of the screen.
- Attach a jumper wire (minimum 16 gauge) across the two terminals on the remote start terminal block. This applies a ground to the controller to close the starting circuit contacts. The engine will crank, start, and run.
- Remove the jumper wire from the remote start terminal block and the engine runs the stop sequence. Reconnect any necessary wires from

the remote start switch (transfer switch) to the remote start terminal block.

- Verify the unit is in AUTO mode. The display screen should show AUTO mode at the top of the screen.
- Switch the main circuit breaker ON (I).
- Secure the unit by closing and locking all access doors.
- The unit is now ready for remote starting.

See [Figure 3-1](#). The remote start terminal block provides a connection for installation of a remote start switch which will allow the unit to be started by a remote dry-contact closure switch. For location of the remote start terminal block, see [Figure 2-3](#).

Before entering AUTO mode, verify the contacts on any remote switch linked to the unit are open. If the contacts on a remote switch are closed, the engine will crank and start when AUTO mode is entered. Attach the switch leads to the two unused terminals (A) on the unit's remote start terminal block.

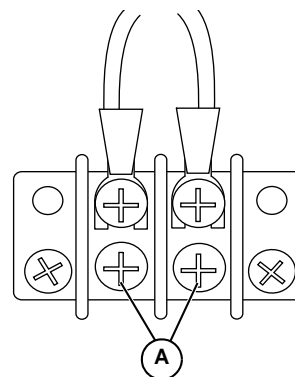

002806

Figure 3-1. Remote Start Terminal Block

Parallel Setup and Operation (If Equipped)

This system is designed to work with generators that are connected on the mobile switching center (MSC) network only and not with the utility or any other independent power source. All other power sources must be isolated from the MSC network to prevent potential damage due to power sources closing out of phase.



002858a

Figure 3-2. Two Units in Parallel

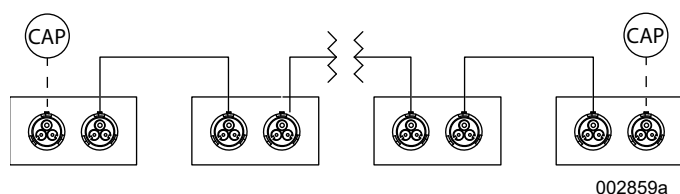

Figure 3-3. Three or More Units in Parallel

Manual Parallel

1. Verify the units to be paralleled are OFF.
2. Secure all electrical connections to each unit and a common bus. Verify all wiring is properly color coded or labeled prior to connection. Any crossed connections will prevent units from paralleling.
3. Connect MSC cable(s) and terminating plugs (resistors) to the end units.
4. Turn the battery disconnect ON.
5. Turn on the controller power for each unit.
6. Put the controller in MANUAL mode (lower left button).
7. Start each unit to be paralleled and allow them to warm up.
8. Press the Close Circuit Breaker button on each unit.

Automatic Parallel

1. Verify the units to be paralleled are OFF.
2. Secure all electrical connections to each unit and a common bus. Verify all wiring is properly color coded or labeled prior to connection. Any crossed connections will prevent units from paralleling.
3. Connect MSC cable(s) and terminating plugs (resistors) to the end units.
4. Turn the battery disconnect ON.
5. Connect two wire start signal (dry contact closure) to all the generators on the MSC network. The contact closure will be in parallel.
6. Turn ON the controller power for each unit.
7. Put the controller in AUTO mode.

Shutting Down the Units in MANUAL Mode

1. Press the Open Circuit Breaker button on each unit to be shut down. Note the controller will ramp off the load before opening the circuit breaker.
2. Allow the engine to cool if previously under heavy load.
3. Press the Engine Stop button.
4. Turn OFF controller power.
5. Turn battery disconnect OFF.

NOTE: If any units are in parallel, do not disconnect the MSC cable.

Low Idle Switch

Engine idle speed is 1,000 to 1,200 rpm. The engine will start at idle speed and run at idle for 15 seconds no matter what position the idle switch is in. After 15 seconds of running at idle, the unit will ramp up to 1,800 rpm if the idle switch is OFF. Otherwise the unit will continue to idle if the idle switch is ON.

When the engine is at idle speed (1,000 rpm), the voltage regulator will not function and the output voltage is dropped out by the voltage regulator.

IMPORTANT NOTE: Do not apply load to the unit when the engine is running at idle speed.

Wet Stacking

The unit is powered by a diesel engine. Diesel engines are susceptible to wet stacking if lightly loaded. Wet stacking occurs when an engine is run at less than 30% of its full load capacity, causing unburned fuel to accumulate in the exhaust system. Wet stacking can be detected by continuous black exhaust when the unit is under a constant load. It can also cause fouling of injectors and buildup on engine valves. Diesel engines operate properly when applied loads are between 30% and 100% capacity. Appropriate generator sizing is determined by the anticipated load. If the unit is in a wet stack condition, load the unit heavily for five hours or until the exhaust is clear.

Cold Weather Operation

The engine may be equipped with a coolant heater, oil pan heater, crankcase ventilation heater, battery heater or fuel heater as cold weather starting aids.

See [Figure 3-4](#). Starting aids are required below 32°F (0°C). They will enhance starting performance below these temperatures and may be needed to start applications that have high parasitic loads during cranking and start acceleration to idle. Other cold weather starting aids are required at temperatures below -13°F (-25°C) or at altitudes above 5,000 ft (1,500 m).

The use of correct grade oil (see [Recommended Oil Types](#)) is critical to achieving adequate cold weather cranking speed. Synthetic oils have improved flow at low temperatures.

The oil pan heater, battery heater and fuel filter heater (if equipped) are activated with a thermostat and will turn on and off as needed. The coolant heater is powered by a shore power 120V electrical connection. The crankcase ventilation heater is powered by the generator and will stay on when the engine is operating in cold weather conditions.

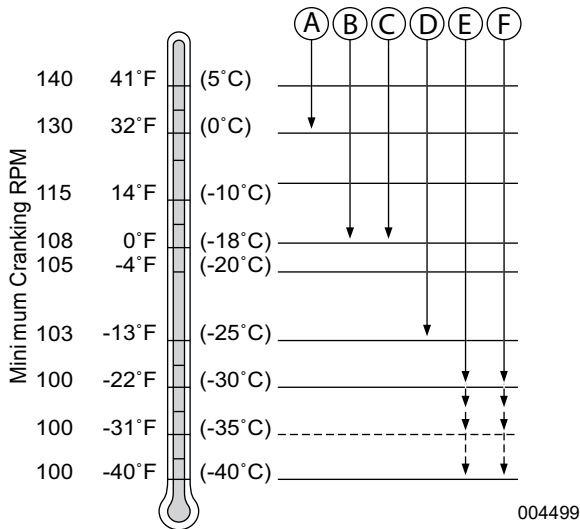

Figure 3-4. Cold Weather Starting Guidelines

A	No aids
B	Electric air heat
C	Block heat
D	Ether
E	Electric air heat and block heat
F	Ether and block heat

Use cold weather starting aids as needed according to [Figure 3-4](#). Follow supplier instructions for starting aids provided on engine. A booster battery can be connected if needed (see [Using a Booster Battery or Charger \(If Equipped\)](#)).

NOTE: Additional information on cold weather operation is available from your local GMASD.

Using a Booster Battery or Charger (If Equipped)



WARNING

Explosion. Batteries emit explosive gases while charging. Keep fire and spark away. Wear protective gear when working with batteries. Failure to do so could result in death or serious injury.

(000137a)



WARNING

Risk of burns. Batteries contain sulfuric acid and can cause severe chemical burns. Wear protective gear when working with batteries. Failure to do so could result in death or serious injury.

(000138a)



CAUTION

Equipment damage. Do not make battery connections in reverse. Doing so will result in equipment damage.

(000167a)

See [Figure 3-5](#). A 12 volt booster battery can be connected in parallel with batteries on the unit to aid in cold weather starting. ALWAYS use heavy-duty jumper cables.

Parallel:

- Amps = Twice as a single battery
- Volts = Same as single battery

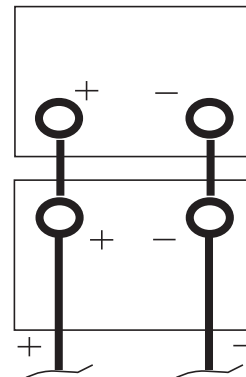

004508

Figure 3-5. Parallel

1. Connect booster battery or batteries to produce the required system voltage.

NOTE: To avoid sparks, do not allow the free ends of jumper cables to touch engine.

2. Connect one end of jumper cable to the POSITIVE (+) post of the booster battery.
3. Connect the other end of the jumper cable to the POSITIVE (+) post of battery connected to starter.
4. Connect one end of the other jumper cable to the NEGATIVE (-) post of the booster battery.
5. Complete the hookup by making the last connection of the NEGATIVE (-) cable to a good ground on the engine frame and away from the battery(ies).
6. Start the engine. Disconnect jumper cables immediately after engine starts. Always disconnect NEGATIVE (-) cable first.

Generator Output Connections

⚠ DANGER

Electrical backfeed. Use only approved switchgear to isolate generator from the normal power source. Failure to do so will result in death, serious injury, and equipment damage.

(000237)



⚠ DANGER

Electrocution. Do not disable or modify the connection box door safety switch. Doing so will result in death or serious injury.

(000157)



⚠ DANGER

Electrocution. Before connections are made to the unit, verify the main circuit breaker and battery disconnect switch are OFF. Failure to do so will result in death or serious injury.

(000156)

⚠ WARNING

Electric shock. Only a trained and licensed electrician should perform wiring and connections to unit. Failure to follow proper installation requirements could result in death, serious injury, and equipment or property damage.

(000155a)

The installation should be in compliance with the national electrical code (NEC), state, and local regulations.

The unit is equipped with connection lugs, located on the lower portion of the control box behind the lug box door. The lugs provide connection points to attach external loads to the generator. A large decal on the inside of the connection lug door details the proper connections for selected voltages.

Connections to the lugs should be made by running the power cables up through the opening in the bottom of the box.

IMPORTANT NOTE: Do not make any connections directly to the lugs without routing the cables through the opening. Use a hex-wrench to tighten the cable connections.

The connection lug door is equipped with safety interlock switches that will trip the main circuit breaker and disable the voltage regulator if the door is opened while the unit is operating.

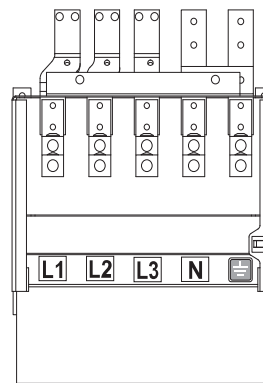

002822

Figure 3-6. Generator Connection Lugs

A ground connection is located next to the connection lugs. The unit must be connected to ground for proper operating safety. The generator neutral is bonded to ground when it is shipped from the factory. The bonding plate must be removed when the generator is used as a standby power source.

Generator Cam Lock Connections (If Equipped)



⚠ DANGER

Electrocution. Before connections are made to the unit, verify the main circuit breaker and battery disconnect switch are OFF. Failure to do so will result in death or serious injury.

(000156)

⚠ DANGER

Electrical backfeed. Use only approved switchgear to isolate generator from the normal power source. Failure to do so will result in death, serious injury, and equipment damage.

(000237)



⚠ WARNING

Electric Shock. Verify all connections to the cam lock receptacles are made to one row only. Failure to do so could result in death, serious injury, and property damage.

(000356)

⚠ WARNING

Electric shock. Only a trained and licensed electrician should perform wiring and connections to unit. Failure to follow proper installation requirements could result in death, serious injury, and equipment or property damage.

(000155a)

The unit may be equipped with cam lock connections located below the receptacles. These receptacles provide connection points to attach external loads to the generator. A decal below the cam lock connections details the proper connections for selected voltages.

Connections should be made by plugging power cables equipped with series 16 taper nose 400A/600V cam lock plugs into the cam lock receptacles. Secure the connection by rotating the plug a 1/2 turn to the right.

L1	Black
L2	Red
L3	Blue
N (Neutral)	White
G (Ground)	Green

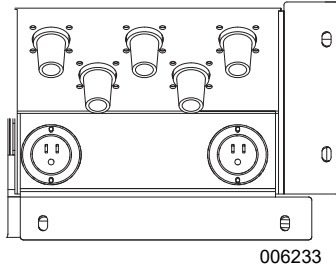

Figure 3-7. Cam Lock Connections



⚠ DANGER

Electrocution. Do not disable or modify the connection box door safety switch. Doing so will result in death or serious injury.

(000157)

A ground connection is located on the far right of the cam lock panel. The unit must be connected to a good earthen ground for proper operating safety. The generator neutral is bonded to ground when it is shipped from the factory. The bonding plate must be removed when the generator is used as a standby power source. Installation should be in compliance with the National Electrical Code (NEC), state, and local regulations.

Using the Voltage Selector Switch



⚠ WARNING

Electric Shock. Never change the voltage selector switch while the engine is running or the controller is on. Doing so could result in death, serious injury or equipment damage.

(000302)

1. Shut down the unit according to [Shutting Down the Unit](#).
2. Remove padlock from voltage selector switch lockout device.
3. Move voltage selector switch to desired voltage.
4. Replace and lock padlock on voltage selector switch lockout device.
5. Start the unit according to [Manually Starting the Unit](#) or [AUTO \(Remote\) Starting the Unit](#).

NOTE: Opening the voltage selector switch box while the unit is running will activate the safety alarm and turn off the unit.

Fine Voltage Adjustment

The fine voltage potentiometer (pot) is on the right control panel. The pot allows for $\pm 10\%$ voltage.

Voltage Regulator

The automatic voltage regulator controls the output of the generator by regulating the current into the exciter field. The voltage regulator is adjusted before shipment from the factory. The regulator has four screwdriver adjustable potentiometers that may be adjusted for under frequency roll-off (U/F), U/F dip (DIP), stability (STAB), and voltage (VOLT). Contact a GMASD for additional information before attempting to adjust the voltage regulator.

NOTE: For units equipped with a Marathon DVR2000E+ automatic voltage regulator, see the Marathon operating manual provided with the unit.

Customer Convenience Receptacles

⚠ CAUTION

Equipment Damage. Verify voltage application before making changes to factory settings. Incorrect voltage applied to a load could result in equipment damage.

(000303)

The unit is equipped with five receptacles. The 240/120VAC twist-lock receptacles are rated at 50A each. The 120VAC duplex receptacles are rated at 20A each, with ground fault circuit interrupt (GFCI) protection. The receptacles are not routed through the main circuit breaker. Each receptacle has its own circuit breaker, located directly above or next to the receptacle. Each breaker is sized to the maximum rating of the corresponding receptacle.

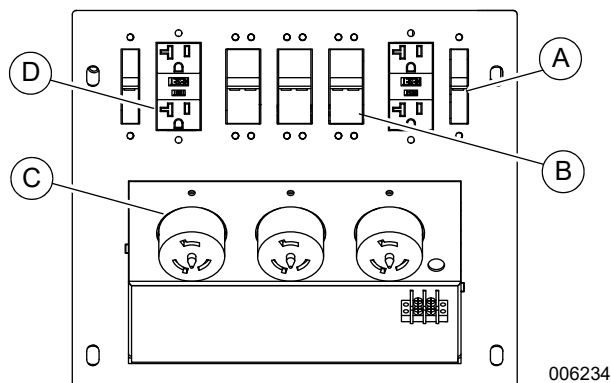

Figure 3-8. Receptacle and Breaker Locations

A	20A circuit breaker (2)
B	50A Circuit breaker (3)
C	120/240V twist-lock receptacle (3)
D	120V GFCI receptacle (2)

NOTE: Power to the receptacles is available any time the generator is running, even if the main circuit breaker is OFF (O). Verify equipment connected to the receptacles is turned OFF before turning the breakers ON (I).

NOTE: When the voltage selector switch is in position for 480/277V 3Ø, voltage at the two GFCI receptacles is 139 volts and the voltage at the three twist-lock receptacles is 240/139 volts. Generac Mobile does not recommend using the receptacles in the 480V position. When the voltage selector switch is in position for 208/120V 3Ø, voltage at the three twist-lock receptacles and the two GFCI receptacles is 208/120 volts.

Main Circuit Breaker

See [Figure 3-9](#). The main circuit breaker is located on the main control panel. When the breaker is OFF (O), power is interrupted to the connection lugs, the optional cam lock receptacles, and the generator. The breaker may be switched ON (I) once the connections have been made to the connection lugs or the optional cam lock receptacles, and the unit has been started and allowed to reach normal operating temperature.

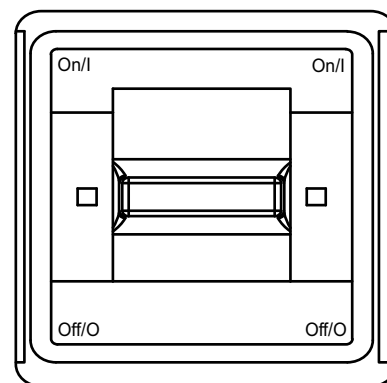

Figure 3-9. Main Circuit Breaker

Reasons the main circuit breaker may trip:

- Overload of the generator circuits to the connection lugs or the optional cam lock receptacles.
- The door covering the connection lugs or the optional cam lock receptacles is opened.
- If the emergency stop switch is activated.

Verify any problems that cause the main circuit breaker to trip are corrected before returning the switch to ON (I).

NOTE: The main circuit breaker only interrupts power to the connection lugs and the optional cam lock receptacles. The customer convenience receptacles have power even if the main circuit breaker is OFF (O). Use the individual circuit breakers located near each receptacle to disconnect power to these receptacles.

DOC and SCR Cleaning Operations



WARNING

Risk of Burn. Stay clear of the exhaust system during operation and exhaust filter cleaning. Exposure to hot exhaust gases and components could result in serious injury. (000304)

When enabled, the exhaust after-treatment system goes through an automatic cleaning process known as regeneration. Under normal circumstances, regeneration occurs without interrupting the unit operation and with minimal operator involvement. In the event there are conditions requiring the operation of the unit with the auto exhaust after-treatment cleaning disabled, the operator may be required to perform procedures to enable or disable the auto exhaust after-treatment cleaning. The operator may also be required to perform a manual regeneration.

NOTE: Always park the unit in a safe location for elevated exhaust temperatures and check for adequate fuel level before beginning the exhaust after-treatment cleaning process. The cleaning cycle can take an extended period of time (approximately 45 minutes).

Cleaning is complete when the regeneration indicator remains off.

Disabling Automatic (AUTO) Exhaust After-Treatment Cleaning

The auto exhaust after-treatment cleaning feature should always be enabled unless doing so would cause an unsafe working environment. In the event that an unsafe working environment occurs, proceed as follows to disable the auto exhaust after-treatment cleaning feature:

1. On the control panel, set the EXHAUST FILTER CLEANING switch to REGENERATION DISABLED (O).
2. Enter the SCR status screen and verify the disabled regeneration indicator appears above the words SCR INHIB - SOLID. See [Selective Catalytic Reduction \(SCR\) Monitoring](#).

NOTE: Disabling auto exhaust after-treatment cleaning is not recommended for any situation unless it is safety related or if the fuel tank lacks the required fuel to complete the cleaning process.

Force a Manual Exhaust After-Treatment Cleaning

If running the unit with the exhaust after-treatment cleaning function disabled, the SCR status screen may display a red alarm, prompting the operator to force a manual exhaust after-treatment cleaning. Proceed as follows to force a manual exhaust after-treatment cleaning:

1. On the control panel, set—and hold for five seconds—the EXHAUST FILTER REGENERATION switch to FORCED REGENERATION (I).
2. Enter the SCR status screen and verify the regeneration indicator appears above the words SCR LAMP - SOLID. See [Selective Catalytic Reduction \(SCR\) Monitoring](#).

Enable Exhaust After-Treatment Cleaning

If the environment no longer requires the exhaust after-treatment cleaning function to be disabled, and there are no alarms present on the SCR status screen, the auto exhaust after-treatment cleaning function should be enabled. Proceed as follows to enable the auto exhaust after-treatment cleaning feature:

1. On the control panel, set the EXHAUST FILTER REGENERATION switch to AUTOMATIC REGENERATION (I/O).
2. Enter the SCR status screen and verify the regeneration indicator appears above the words SCR LAMP - SOLID. See [Selective Catalytic Reduction \(SCR\) Monitoring](#).

Transfer Switch



Loss of life. Property damage. Installation must always comply with applicable codes, standards, laws and regulations. Failure to do so will result in death or serious injury. (000190)



Electrical backfeed. Use only approved switchgear to isolate generator from the normal power source. Failure to do so will result in death, serious injury, and equipment damage. (000237)



Electric shock. Only a trained and licensed electrician should perform wiring and connections to unit. Failure to follow proper installation requirements could result in death, serious injury, and equipment or property damage. (000155a)



Electric shock. Phase rotation must be compatible. Incompatible phase rotation could result in death, serious injury, or equipment damage. (000226b)

The installation should be in compliance with the National Electrical Code (NEC), state, and local regulations.

Before any connections are attempted, verify the main circuit breaker and the control power switch are in the OFF (O) position and that the negative (-) battery cable has been disconnected from the battery.

Installation of such devices must be performed by following all directions supplied by the manufacturer of the switch. If attaching the unit to a power supply normally serviced by a utility company, notify the utility company and check state and local regulations. Familiarize yourself with all instructions and warning labels supplied with the switch.

When the unit is used as a standby power supply, it must be equipped with a transfer switch that isolates it from the utility's distribution system. A transfer switch is designed to transfer electrical loads from the normal power source (utility) to the emergency power source (generator) when normal voltage falls below a prescribed level. The

transfer switch automatically returns the load back to the normal source when power is restored back to operating levels.

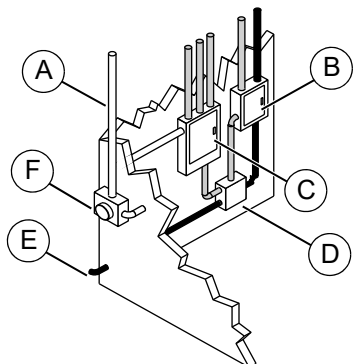

002807

Figure 3-10. Transfer Switch Operation

A	Incoming utility power
B	Emergency distribution panel (generator power)
C	Main distribution panel (utility power)
D	Transfer switch
E	Power from generator
F	Utility meter
WHITE	Incoming utility power
GRAY	Normal utility power circuit
BLACK	Emergency generator power circuit

Using Extended Run Fuel and DEF System (If Equipped)

See **Figure 3-11**. Four components comprise the extended run fuel and DEF system.

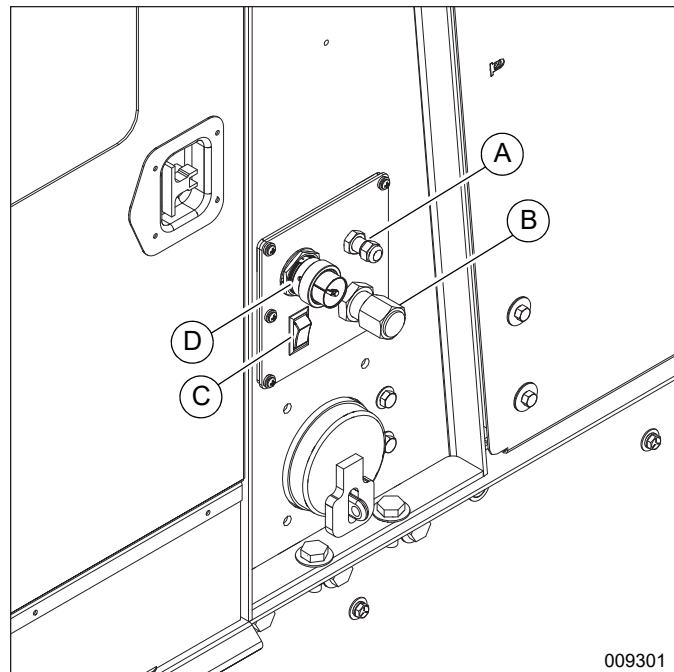

009301

Figure 3-11. Extended Run Fuel and DEF System—Connection Panel Components

A	External DEF Input 9/16-18 37° flare fitting (male)
B	External Fuel Input 1 1/16-12 37° flare fitting (male)
C	System enable switch
D	DEF Transfer Power Bulkhead Connector Deutsch HD34-18-14PN For external DEF pump and heating system

1. Verify unit is OFF.
2. If connecting external DEF tank, ensure external DEF tank pump and heating system are compatible with electrical interface (D).

IMPORTANT NOTE: For external DEF tank heating, the 50A-125/250VAC twist-lock plug from tank manufacturer must be plugged into generator.

3. Start unit. Verify controller displays status *Generator Available*.
4. Connect external tanks to appropriate inputs (A, B).

NOTE: Double-check hose connections—verify secure connection to respective inputs (A, B).

5. Connect electrical harness, provided with external DEF tank, to bulkhead connector (D).
6. Switch the system enable switch (C) to ON.

NOTE: Fluid level in each on-board tank determines when the respective pump switches on and off.

NOTE: When external tanks are not connected, the system enable switch (C) should be switched to OFF, preventing fuel pump activation and controller faults.

NOTE: If faults occur, reset the system by switching the system enable switch (C) OFF and ON.

AUTO Exercise Timer

The controller is capable of starting and stopping the unit automatically, based on a programmable schedule.

Units installed in a standby application should be exercised regularly to maintain operating condition and to ensure responsiveness in an emergency situation. Proceed as follows to operate the unit in AUTO mode:

Accessing the Configuration Menu

1. With the unit stopped, press ▲, ►, ▼, or ◀ to navigate to the maintenance screens from any of the operator screens.
2. While on any maintenance screen, press ✓ and O simultaneously. The controller will display the Configuration menu.
3. To save any changes and exit the Configuration menu, press and hold ✓ for five seconds. To cancel any changes and return to the maintenance screen, press and hold O for five seconds.

Set the Controller Clock

The schedule runs based on the time set in the controller clock. Proceed as follows to set the controller clock before setting the schedule:

1. Navigate to the maintenance group and press ► to access it.
2. Press ► to select the time section.
3. Set the time and date to the correct local time.

Set the Schedule

NOTE: The controller must be in AUTO mode to run at the programmed time. Use a trickle or solar battery charger to prevent the controller from draining the battery while in AUTO mode.

1. Access the scheduler group by pressing the ► button.

NOTE: The scheduler group consists of the scheduler options and scheduler setup sections. Each section can be accessed and exited using the ► and ◀ buttons.

2. Access the scheduler options section. Within this section, the scheduler can be enabled, run mode selected, and load mode selected.

Item	Values
Enable	Yes, No
Run Mode	Monthly, Weekly
Load	Idle, In Island, On Load, Off Load

3. Access the scheduler setup section. In this section, each schedule entry can be modified by pressing the ✓ button to select the item, and the ▲ and ▼ buttons to define them.

Item	Values
Schedule Entry	1–16
Start Time	00:00–23:59
Duration	00:00–99:59
Day	Monday–Sunday
Week (of month)	First, Second, Third, Fourth

NOTE: If setting up a daily scheduled run, select Weekly Run Mode, then set start time and duration for each day (seven schedule entries total). This will repeat the seven day schedule as long as the unit is in AUTO mode.

Setting Up a Daily Scheduled Run

1. Enable the scheduler.
2. Set RUN mode to Weekly.
3. Set load to preferred method.
4. Set the start time and duration for seven days (Monday–Sunday).
5. Set the controller to AUTO mode.

Set the Unit to AUTO Mode

From any operator or maintenance screen, press and hold the AUTO or MANUAL mode (⏻) button for five seconds, or until AUTO mode is displayed at the top of the screen.

NOTE: If any of the scheduled time slots are currently active, the controller will begin the starting sequence and start the unit, provided there are no shutdown conditions present.

Shutting Down the Unit

Prior to shutting down the unit, check with personnel using power supplied by the generator and let them know the power is going to be turned off. Verify the power shut

down will not create any hazards by accidentally turning off equipment that needs to be kept on (pumps, compressors, lights, and so forth).

1. Remove all loads from the generator by opening all circuit breakers (turn OFF (O)).
2. Allow engine to run for approximately five minutes to allow it to cool down.
3. Press the red engine STOP (O) button on the controller. This will result in the generator going into the shutdown cycle and starting a 15 second shutdown timer. If the unit does not shut down within 15 seconds, a stop fail alarm will be displayed on the display screen.
4. After the unit shuts down, wait two minutes after engine shutdown for controller actuated actions to complete and then set the control power switch to OFF (O).

NOTE: The ECU needs to run for 90 seconds after shutdown to purge the DEF.

NOTE: Turning off the control panel before the controller finishes updating could cause a loss of data.

NOTE: For extended storage time, disconnect the battery. See the engine operator's manual for extended storage requirements.

Emergency Stop Switch



Equipment Damage. The emergency stop switch is not to be used to power down the unit under normal operating circumstances. Doing so could result in equipment damage.

(000246b)

See **Figure 3-12**. The unit is equipped with one emergency stop switch. The red button is clearly labeled EMERGENCY STOP. The switch can be accessed and activated with all doors closed and locked.

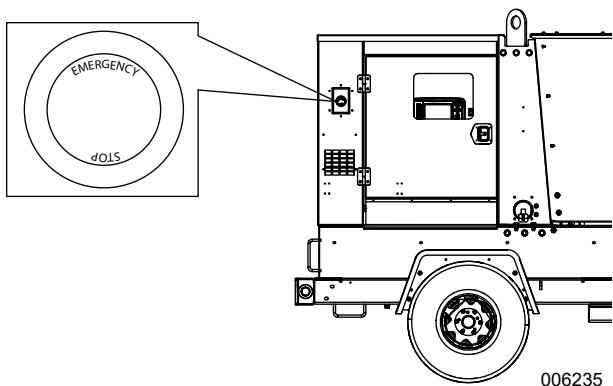

Figure 3-12. Emergency Stop Switch

Activate the emergency stop switch by pushing the button in until it locks down. This trips the main circuit breaker which then opens the contact, disconnecting the

load to the connection lugs. This will also open the fuel circuit, shutting down the engine. The emergency stop fault will be displayed on the control panel. The switch will remain closed until it is pulled out.

Using the ECU Override Switch



Equipment Damage. Do not start the engine with the Engine Control Unit (ECU) override switch ON. Doing so will damage the ECU.

(000305)

IMPORTANT NOTE: Starting the engine with the ECU override switch ON will not allow the engine to shut down properly using the Engine STOP Button. This must only be used when the engine is OFF.

The ECU override switch is located behind the controller panel. This toggle switch powers up the ECU without having to start the engine. Use the ECU override switch to turn the ECU OFF. If the unit needs to be shut down immediately, use the emergency stop switch. See **Emergency Stop Switch**.

Front Hood Operation



Crushing Hazard. Stay clear of hood and lift structure when opening and closing generator hoods. Failure to do so could result in death or serious injury.

(000300)

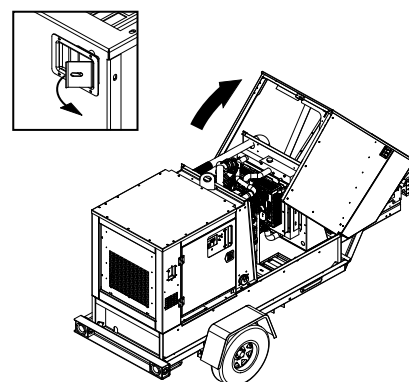

002802

Figure 3-13. Front Hood Operation

To Open the Front Hood

1. See **Figure 3-13**. With your right hand, grip the handle located on the front panel.
2. With your left hand, pull the hood latch located on the upper corner of the hood. Tilt the hood open until it contacts the bulkhead panel.

To Close the Front Hood



⚠ WARNING

Crushing Hazard. Do not attempt to close the hood from sides of unit. Failure to close hood correctly could result in serious injury or equipment damage. (000301)

1. Verify the skid is free of debris and all personnel are clear of unit.
2. While standing at the front of the unit, slowly push the hood forward until firmly closed.
3. Verify the hood is securely closed by attempting to open without pulling the hood latch.

Towing the Unit

⚠ WARNING

Personal injury. Trailer must be securely coupled to the hitch with the chains correctly attached. Uncoupled or unchained towing could result in death or serious injury. (000233a)

⚠ WARNING

Personal injury. Do not operate unit during transport. Doing so could result in death, serious injury, or property damage. (000231a)

⚠ WARNING

Crushing hazard. Verify unit is properly secured and on level ground. An unsecured unit can suddenly roll or move, causing death or serious injury. (000234a)

1. Verify the engine is OFF.
2. Use the tongue jack to raise or lower the trailer onto the hitch of the towing vehicle. Lock the hitch coupling and attach the safety chains or cables to the vehicle. Release the jack locking pin and rotate the jack into the travel position. Verify the locking pin snaps into place.

NOTE: A film of grease on the coupler will extend coupler life and eliminate squeaking. Wipe the coupler clean and apply fresh grease each time the unit is towed.

3. Lubricate the grease fittings located on the leveling jacks to verify proper operation of the jacks. See **Jack Maintenance**. For maintenance interval information, see **Basic Maintenance Schedule**.
4. Connect trailer wiring to the tow vehicle. Check for proper operation of the directional and brake lights.
5. Verify all doors and hoods are properly latched.

6. Check for proper inflation of the trailer tires. Proper inflation is specified in **Specifications**.
7. Check the wheel lugs. Tighten or replace any lugs that are loose or missing. If a tire has been removed for axle service or replaced, tighten the lugs in the order shown in **Figure 3-14** to the following specifications:
 - a. Start all lug nuts by hand.
 - b. First pass tighten to 20–25 ft-lb (27–33 Nm).
 - c. Second pass tighten to 50–60 ft-lb (67–81 Nm).
 - d. Third pass tighten to 90–120 ft-lb (122–162 Nm).

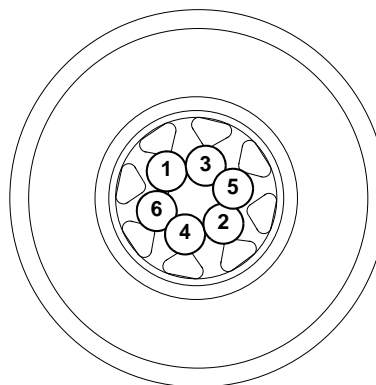

006236

Figure 3-14. Lug Sequence

⚠ WARNING

Property or Equipment Damage. Tighten wheel lug nuts after first 50 miles to factory specifications. Failure to do so could result in death, serious injury, property or equipment damage. (000235)

NOTE: Maximum recommended speed for highway towing is 45 mph (72 km/h). Recommended off-road towing speed is 10 mph (16 km/h).

Lifting the Unit



⚠ WARNING

Personal injury. Failure to properly connect lifting cables, chains, or straps could result in death, serious injury, or property damage.

(000346)

⚠ WARNING

Personal Injury. Do not use lifting eye if there are signs of damage or corrosion. Doing so could result in death, serious injury, or property damage.

(000433)

⚠ WARNING

Personal Injury. Do not use lifting eye other than as directed. Doing so could result in death, serious injury, or property damage.

(000434)

1. Verify the equipment being used to lift the unit is in good condition and has sufficient capacity. For approximate weights, see [Specifications](#).
2. Close and lock all hoods and doors.

IMPORTANT NOTE: Always remain aware of people and objects around the work site when moving or lifting the unit.

3. See [Figure 3-15](#) for location of the central lift point (A).
4. Attach any slings, chains, or hooks directly to the central lift point.

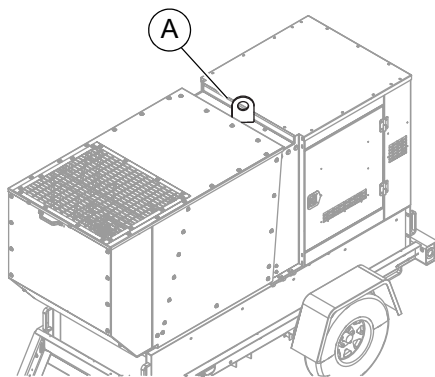

006237

Figure 3-15. Lifting Points

Tying Down the Unit

When securing the unit for transportation, verify the equipment being used to fasten the unit is in good condition and has sufficient strength to hold the unit in place during transport.

See [Figure 3-16](#). Use the tie-down points (A) as shown.

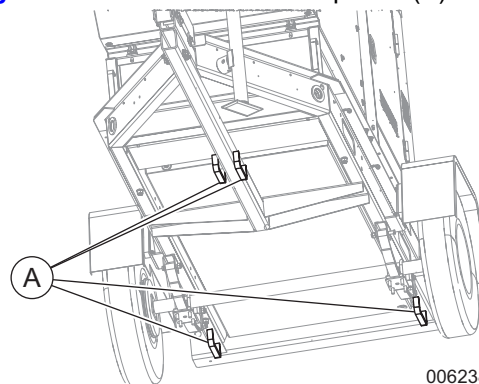

006238

Figure 3-16. Tie-Down Points

Section 4: Maintenance

Emissions Information

For emissions information, see the OEM diesel engine manual.

Maintenance

Regular maintenance will improve performance and extend engine/equipment life. Generac Mobile Products, LLC recommends that all maintenance work be performed by a Generac Mobile Authorized Service Dealer (GMASD). Regular maintenance, replacement, or repair of the emissions control devices and systems may be performed by any repair shop or person of the owner's choosing. To obtain emissions control warranty service free of charge, the work must be performed by a GMASD. See the emissions warranty.

Daily Walk Around Inspection



Equipment Damage. Failure to perform a daily inspection could result in damage to the unit.

(000306)

Inspect for conditions that could hinder performance or safety, such as (but not limited to) oil, coolant, and fuel leakage, blocked vents, loose or missing hardware, and improper electrical connections.

Inspect the fan belt for signs of cracking, fraying, and stretching, and verify the belt is properly seated in the pulley grooves. Replace the belt according to the manufacturer's recommendations.

NOTE: At the 500 hour or 12 month service interval, it is recommended that the belt be removed and checked for wear. While the belt is removed, inspect pulleys and bearings. Rotate and feel for hard turning or unusual sounds. Contact the engine manufacturer if pulleys or bearings need replacement.

Belt Tensioners

John Deere engines use two types of belt tensioners: manual and automatic. Adjust the belt using the manual tensioner according to the manufacturer's specifications. The automatic tensioner cannot be adjusted or repaired and is designed to maintain proper tension over the belt's life. Units with an automatic belt tensioner must be inspected according to the manufacturer's specifications.

General Maintenance

Poorly maintained equipment can become a safety hazard. Periodic maintenance and occasional repairs are necessary in order for the equipment to operate safely and properly over a long period of time. Never perform any routine service (oil and oil filter changes, cleaning, and so forth) unless all electrical components are shut off. Before servicing the unit, always follow the instructions listed below.

- Verify the control power switch is turned OFF (O).
- Verify the circuit breakers are turned OFF (O).
- Activate (push in) the emergency stop switch.
- Disconnect the negative (-) terminal on the battery.
- Attach a DO NOT USE sign to the control panel. This signifies that the unit is being serviced and reduces the chance of someone inadvertently trying to start the unit.
- Do not wash the unit with a high pressure hose or with any kind of power washer.
- Do not wash the engine block or fuel tank with a power washer or steam cleaner. Water may enter the cabinet and collect in the generator windings or other electrical parts, causing damage.
- Inspect for water inside the cabinet and generator before each use if the unit is stored outside. If wet, dry the unit thoroughly before starting.
- Inspect condition of electrical cords. **DO NOT** use the unit if insulation is cut or worn through.
- Verify the condition of the air filter by viewing the level of the vacuum draw on the filter minder gauge. Replace the air filter when the yellow center bar reaches the red section on the gauge (20 in. H₂O).
- Inspect wheel lugs. See [Towing the Unit](#).
- Inspect wheel bearings. See [Trailer Wheel Bearings](#).
- Inspect the wheel bearings for unusual wear.
- Inspect coolant level daily. See the engine operator's manual for coolant recommendations and proper mixture.
 - Visually inspect the level in the coolant overflow tank located near the radiator.
 - Normal operating level is between the FULL and ADD markings on the overflow jug.
 - When engine is stopped and completely cool, coolant may be added directly to the coolant overflow container.

- Check the oil level daily. See the engine operator’s manual for the proper viscosity grade of oil, including special operating conditions such as a change in season or climate.
- **DO NOT** start the unit if the engine oil level is below the add mark on the dipstick.
- Normal operating level is in the cross-hatch pattern between the FULL and ADD markings on the dipstick.
- Add oil only if the oil level is below the ADD mark on the bottom of the cross-hatch pattern on the dipstick.
- **DO NOT OVERFILL** the crankcase.
- Verify the fuel level.
- Verify the remote switch is also off and tagged if the unit is connected to a remote start or transfer switch.

NOTE: If the engine was run out of fuel, or the fuel tank was drained, it may be necessary to purge the fuel lines. See the engine operator’s manual supplied with the unit for more information.

Engine Oil Recommendations

The engine oil should be serviced in accordance with the recommendations of this manual to maintain the product warranty.

The engine has been filled with factory engine oil of a grade recommended by the engine supplier.

Use a high quality detergent oil with an appropriate classification and viscosity for the engine type and ambient temperature conditions. Contact a GMASD or refer to the applicable engine service manual for more information.

Recommended Oil Types

- Plus-50™ Oils: John Deere Plus-50, John Deere Plus-50 II
- Other Oils: John Deere Torq-Gard™ Supreme, API CJ-4, API CI-4 PLUS, API CI-4, API CH-4, ACEA E9, ACEA E7, ACEA E6, ACEA E5, ACEA E4

NOTE: The 500 hour extended oil and filter change interval is only allowed if all of the following conditions are met:

- Engine equipped with extended drain interval oil pan.
- Use of diesel fuel with sulfur content less than 2000 mg/kg (2000 ppm).
- Use of John Deere Plus-50™ II or John Deere Plus-50™ oil.
- Use of an approved John Deere oil filter.

Coolant Recommendation



⚠ DANGER

Risk of poisoning. Do not use mouth to siphon coolant. Doing so will result in death or serious injury.

(000149)



⚠ WARNING

Risk of burns. Do not open coolant system until engine has completely cooled. Doing so could result in serious injury.

(000154)

⚠ CAUTION

Risk of overheating. Do not use any chromate base rust inhibitor with propylene glycol base antifreeze, boosters, or additives. Doing so will cause overheating and possible equipment damage.

(000165a)

Contact a GMASD or refer to the applicable engine service manual for engine coolant recommendations. See table below for mixtures:

Freezing Point °F (°C)	-12 (-24)	-34 (-36)	-54 (-48)	-90 (-67)
Water (% Volume)	50	40	40	40
Antifreeze (% Volume)	50	60	60	60*

* Maximum freeze protection is at 60%.

Basic Maintenance Schedule

See the original equipment manufacturer's operating manual for a complete list of maintenance requirements. Failure to comply with the procedures as described in the engine operator's manual will nullify the warranty, decrease performance, and cause equipment damage or

premature equipment failure. Maintenance records may be required to complete a warranty request.

IMPORTANT NOTE: Refer to the engine operator's manual for additional maintenance information.

Basic Maintenance Schedule—John Deere Engine

Item	Daily	Every 250 Hr	Every 500 Hr/12 Mo	Every 3,000 Hr/36 Mo	Every 4,500 Hr/36 Mo	As Required
Check engine oil level	◆					
Check engine coolant level	◆					
Check fuel level	◆					
Check tire pressure	◆					
Check all electrical connections	◆					
Inspect radiator fins for debris; clean as required	◆					
Drain water from fuel filters	◆					
Perform Daily Walk Around Inspection	◆					
Check oil vapor recirculation system/non-return valve		◆				
Change engine oil and replace oil filter		◆*				
Replace oil vapor recirculation filter			◆			
Service battery			◆			
Replace fuel filter elements			◆			
Check engine mounts			◆			
Check air intake hoses, connections and system			◆			
Check engine electrical ground connection			◆			
Check automatic belt tensioner and belt wear			◆			
Check cooling system			◆			
Lubricate leveling jacks			◆			
Check Generator Drive Plate Torque			◆			
Test thermostats			◆			
Inspect wheel bearings			◆**			
Replace air cleaner elements				◆		
Change DEF dosing unit filter					◆	
Replace alternator and fan belts						◆
Check fuses						◆
Add coolant						◆
Bleed fuel system						◆
Clean DEF tank						◆
Service air cleaner filter elements						◆
Replace after-treatment DEF tank header suction screen						◆
Replace after-treatment DEF dosing system coolant filter						◆

* Change the oil and oil filter after the first 100 hours, then every 250 hours. If John Deere Plus 50 II engine oil is used, the interval can be increased to every 500 hours.

** Increased inspections required under dusty or damp conditions. See **Trailer Wheel Bearings** for more information.

Engine Break-In Requirements

NOTE: During the first 20 hours of operation, avoid long periods of no load or sustained maximum load operation. If the generator is to run for longer than five minutes without a load, shut down the generator.

John Deere engines are supplied with engine break-in oil from the factory. Extra care during the first 100-500 hours of engine operation will result in better performance and longer engine life. Do not exceed 500 hours of operation with the break-in oil. Operate the engine at heavy loads (60–90% of maximum) as much as possible. If the engine has spent significant time at idle, constant speed(s), or light load, or if makeup oil is required, a longer break in period may be needed. Refer to the engine operator's manual for a full description of necessary procedures on the addition of break-in oil and extension of the break-in period. For more information on regular maintenance intervals, refer to [Basic Maintenance Schedule—John Deere Engine](#).

Resetting the Maintenance Alarms

The controller will display a warning message when the unit is due for maintenance or service. The maintenance or service interval is set at 250, 500 and 3,000 hours of engine running time. Once the unit has been serviced, the appropriate maintenance alarm reminder must be reset. Proceed as follows to reset the maintenance alarms:

1. With the unit shut down, move the control power switch to CONTROL ON (I). The controller will toggle automatically to the home screen after initialization.
2. Press ▲, ►, ▼, or ◀ to enter the maintenance screens.
3. Press ✓ and O simultaneously. The next screen displays the Configuration menu.
4. Press ▼ to move the cursor (blue highlighted text) down to the maintenance group.
5. Press ► to access the sections. Press ▼ to highlight the maintenance section.
6. Press ► to access the parameters and highlight the maintenance alarm that needs to be reset.
7. Press ✓ to select the editable parameters. The cursor will highlight NOT RESET under the selected maintenance alarm. Press ▲ to highlight RESET.
8. Press ✓ to reset the selected maintenance alarm.
9. To perform additional maintenance alarm resets, repeat steps 6–8.

NOTE: If the selected maintenance alarm does not need to be reset, press ▼ to highlight Not Reset and press ✓ to return to the parameters section.

10. Press and hold ✓ for five seconds to save changes. Press and hold O for five seconds to discard changes made.

Testing DEF

NOTE: Using DEF with the correct concentration is critical to engine and after-treatment system performance. Extended storage and other conditions can adversely alter the DEF concentration.

If DEF quality is questionable, draw a sample out of the DEF tank or storage tank into a clear container. DEF must be crystal clear. If DEF appears cloudy or has a colored tint, it is likely not within specification. DEF in this condition should not be used. Drain the tank, flush with distilled water, and fill with new DEF. After filling the tank, check DEF concentration.

If the DEF passes the visual and smell tests, check the DEF concentration with a handheld refractometer calibrated to measure DEF.

DEF concentration should be checked when the engine has been stored for extended periods, or if there is suspicion the engine or packaged DEF has been contaminated with water.

Two approved tools are available through your John Deere dealer:

- JDG11594 Digital DEF Refractometer—A digital tool providing an easy to read concentration measurement.
- JDG11684 DEF Refractometer—A low-cost alternative tool providing an analog reading.

Follow the instructions included with either tool to obtain the measurement.

The correct DEF concentration is 31.8–33.2% urea. If the DEF concentration is not within specification, drain the DEF tank, flush with distilled water, and fill with new or good DEF. If packaged DEF is not within specification, dispose of DEF packages and replace with new or good DEF.

NOTE: Do not create DEF by mixing agricultural grade urea with water. Agricultural grade urea does not meet the necessary specifications and can damage the after treatment system.

DEF Tank Cleaning

Proceed as follows to clean the DEF tank:

1. Drain DEF tank into a suitable container. See [Disposal of DEF](#).
2. Flush DEF tank with distilled water, and fill with new or good DEF.

Disposal of DEF

Large amounts of DEF should be contained. If large spills occur, contact local environmental authorities for assistance with clean up.

If a substantial quantity of DEF is not within specification, contact the DEF supplier for assistance with disposal. Do not dump large quantities of DEF onto the ground or send DEF to wastewater treatment facilities.

Check Generator Drive Plate Torque

1. Disconnect battery.
2. Remove generator fan guard.
3. Tighten each of the drive plate bolts to 40 ft-lb (54 Nm).
4. Install generator fan guard.
5. Connect battery.

Jack Maintenance

The following procedures should be performed annually.

Side-Wind Models

- The internal gearing and bushings of the jack must be kept lubricated. Apply a small amount of automotive grease to the internal gearing by removing the jack cover, or if equipped, use a needle nose applicator or standard grease gun on the lubrication point on the side of the jack near the crank. Rotate the jack handle to distribute the grease evenly.
- A lightweight oil must be applied to the handle unit at both sides of the tube.
- If equipped, the axle bolt and nut assembly of the caster wheel must also be lubricated with the same lightweight oil.

Top-Wind Models

- Apply a lightweight oil to the screw stem.

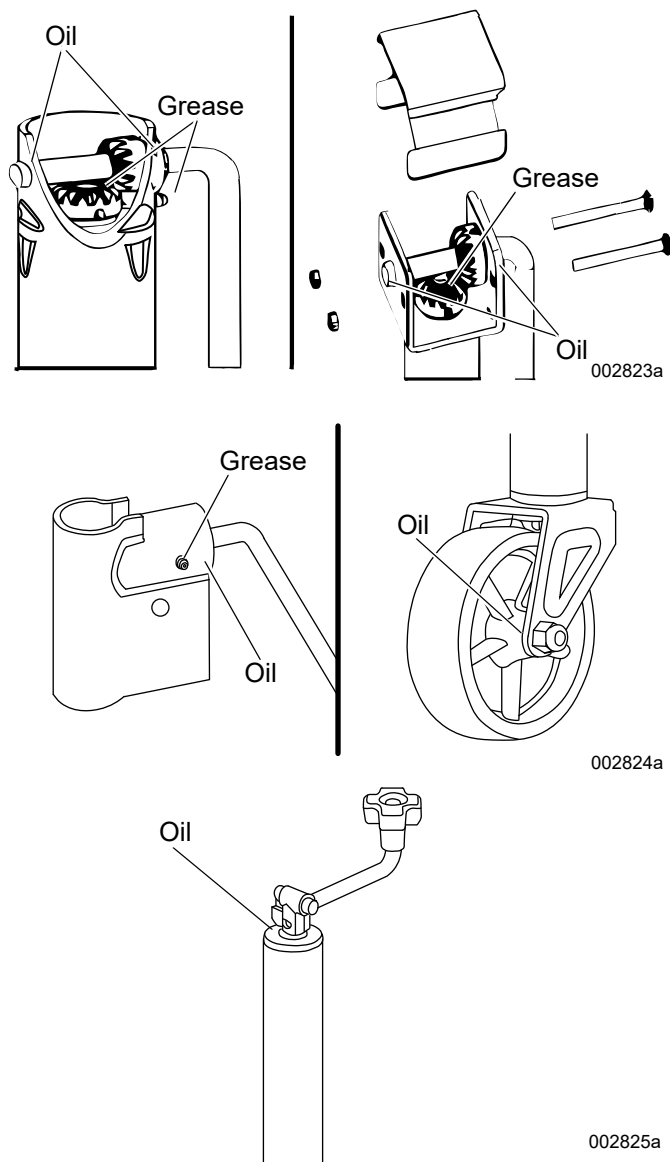

Figure 4-1. Lubrication Points

Trailer Wheel Bearings

The trailer axles are equipped with a grease fitting to allow lubrication of the wheel bearings without needing to disassemble the axle hub. To lubricate the axle bearings, remove the small rubber plug on the grease cap, attach a standard grease gun fitting to the grease fitting, and pump grease into the fitting until new grease is visible around the nozzle of the grease gun. Use only a high quality grease made specifically for lubrication of wheel bearings. Wipe any excess grease from the hub with a clean cloth and replace the rubber plug when finished. The minimum recommended lubrication is every 12 months or 12,000 miles (19,312 km). More frequent lubrication may be required under extremely dusty or damp operating conditions.

This page intentionally left blank.

Section 5: Troubleshooting

General Troubleshooting

This information is intended to be a check or verification for simple causes that can be located and fixed. It does not cover all types of problems. See the engine operator's

manual for additional troubleshooting information. Procedures that require in-depth knowledge or skills should be performed by a GMASD.

Problem	Possible Cause	Solution
Low Fuel Level Shutdown	<p>Low fuel level</p> <p>Unit not level</p> <p>Fuel tank leaking</p> <p>Damaged fuel sender or wiring</p>	<p>Check fuel level in LCD window of controller.</p> <p>Confirm that unit is sitting level to ensure an accurate reading.</p> <p>Check tank for leaks.</p> <p>Check for continuity between sender and engine controller. (See DC Wiring.)</p>
Low Oil Pressure Shutdown	<p>Low oil level</p> <p>Oil leaking from engine</p> <p>Oil pressure sender</p>	<p>Check oil level on dipstick. Add oil, if needed.</p> <p>Visually inspect the engine for leaks. Restart unit and verify loss of pressure. Shut down immediately if pressure does not reach 5 psi (34 kPa) within five seconds.</p> <p>See engine operator's manual to identify corrective action.</p>
Low Coolant Level Shutdown	<p>Low coolant level</p> <p>Coolant hoses leaking</p> <p>Engine block or water pump leaking</p>	<p>Allow engine to cool, then check coolant level in radiator. Add coolant, if needed.</p> <p>Inspect hoses for leaks. Repair or replace as necessary.</p> <p>Visually inspect for leaks. Verify no coolant has mixed with the engine oil (oil will appear milky). See engine operator's manual for additional information.</p>
High Coolant Temperature Shutdown	<p>Low coolant level</p> <p>Blockage in radiator</p> <p>Leakage in coolant hoses, engine block, or water pump</p>	<p>Add coolant if needed. Allow engine to cool, then check coolant level in radiator. Restart engine and check coolant temperature (on controller). Stop engine immediately if coolant temperature is 210°F (99°C) or more.</p> <p>Check radiator shroud and ducting for blockage and remove any foreign matter.</p> <p>Inspect for visible leaks. Check tension of water pump serpentine drive belt.</p> <p>Remove load on generator and restart engine. Check coolant temperature and shut engine down immediately if it starts to over-heat (230 degrees or higher). See the engine operator's manual for additional information on engine overheating.</p>
Overcrank Shutdown	Fuel level low	<p>Check fuel level in tank.</p> <p>Check fuel pump operation.</p> <p>Check air filter for blockage.</p> <p>See engine operator's manual for additional information.</p>

This page intentionally blank

Section 6: Wiring Diagrams

Wiring Diagrams

GROUP G

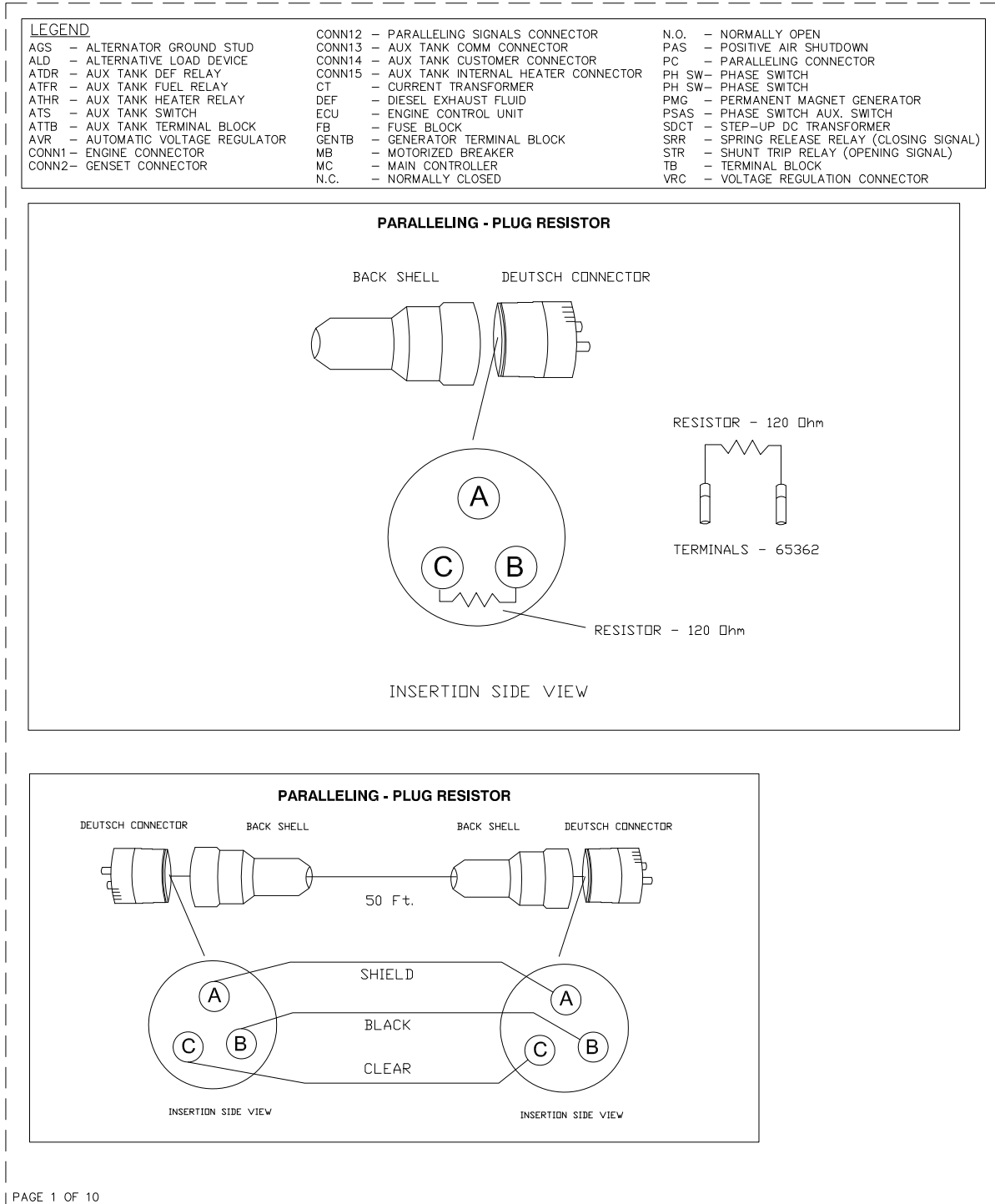

REVISION: C
DATE: 8/25/18

PAGE 1 OF 10

WIRING - DIAGRAM
MDG100/75 DF4
DRAWING #: 10000020202

COMPONENTS LOCATED INSIDE CONTROLS DOOR

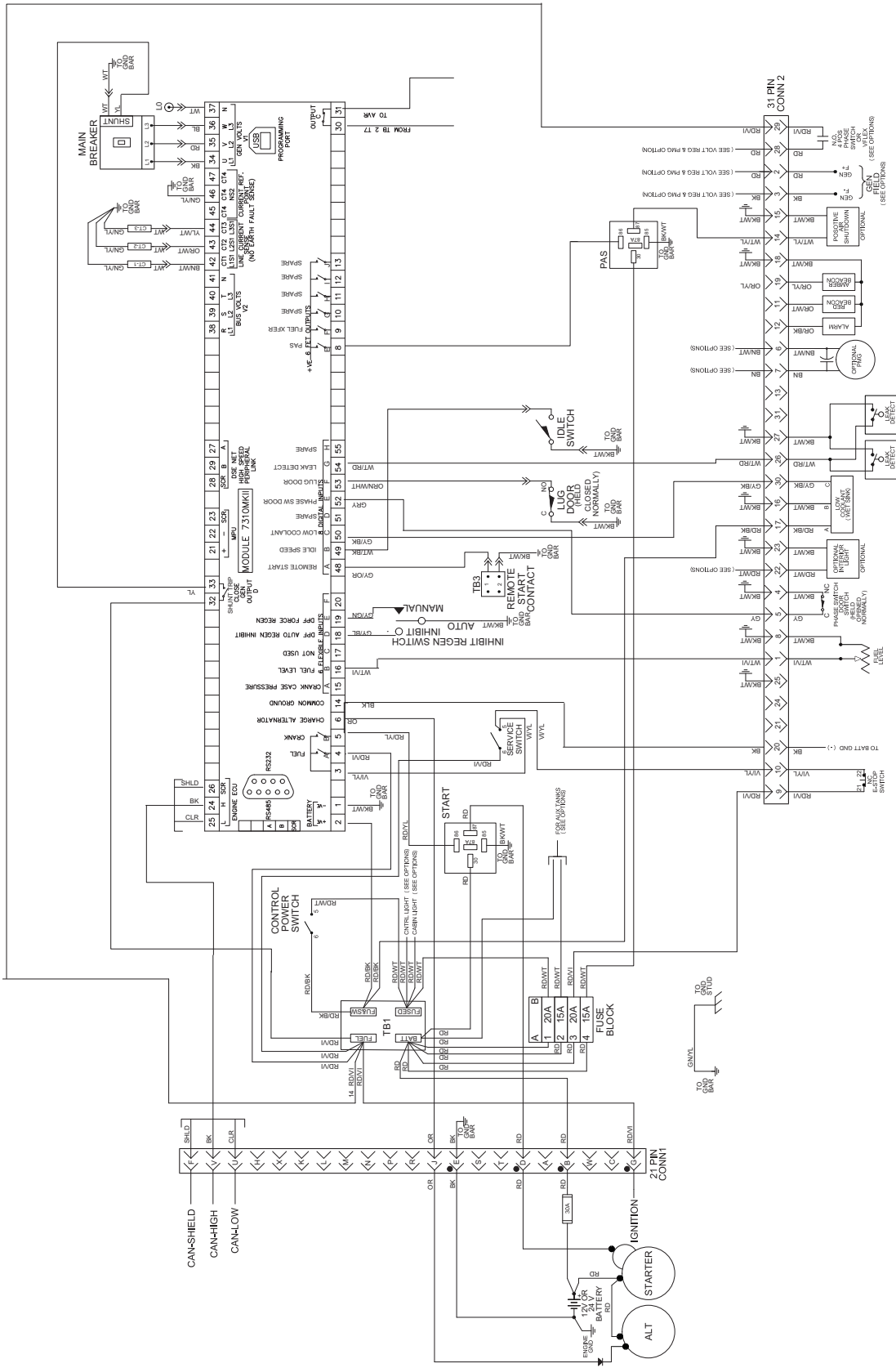

A0000635350_A_02.27.20

GROUP G

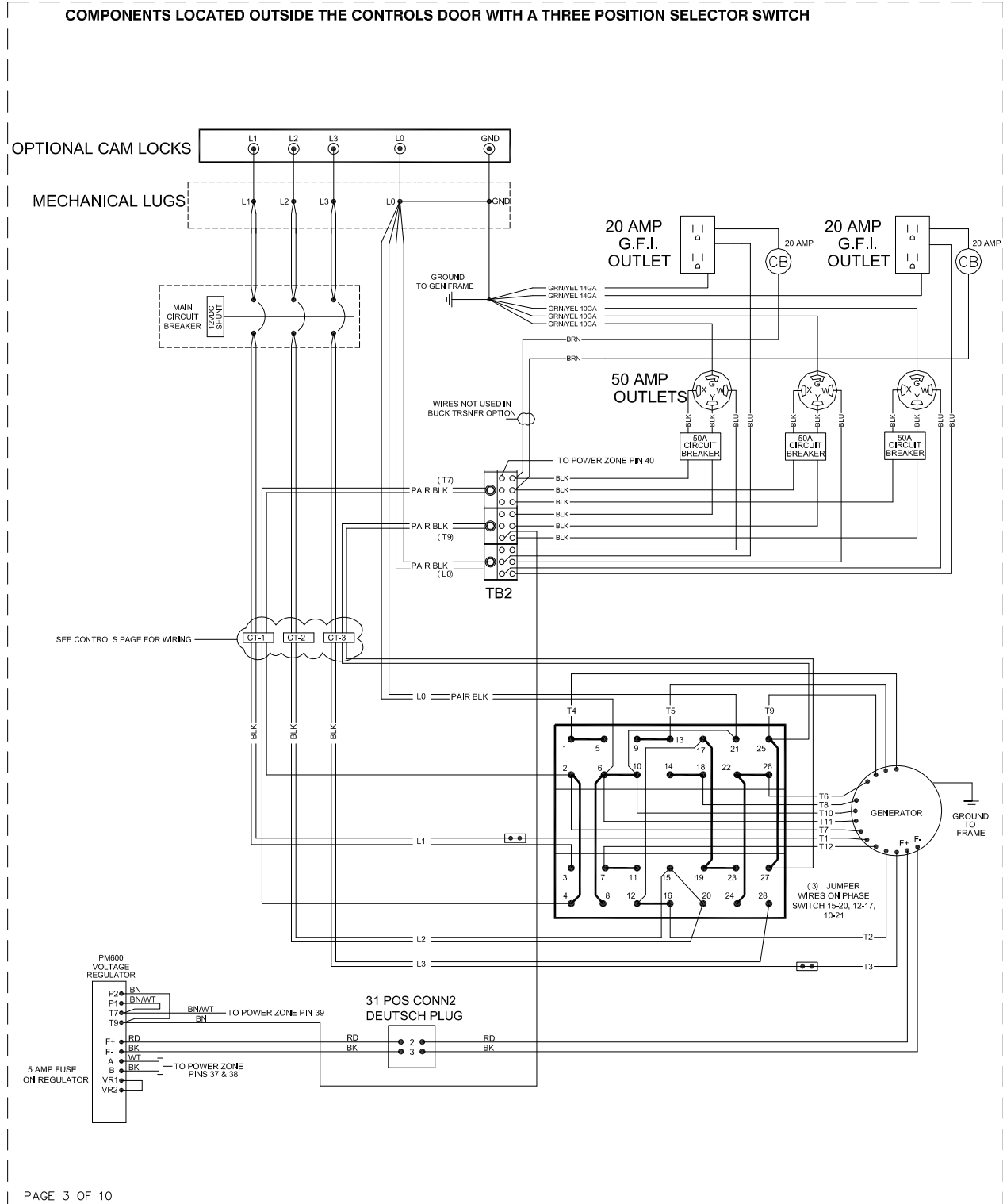

PAGE 3 OF 10

REVISION: C
DATE: 7/5/17

PAGE 3 OF 10

WIRING - DIAGRAM
MDG100/75 DF4
DRAWING #: 1000020202

GROUP G

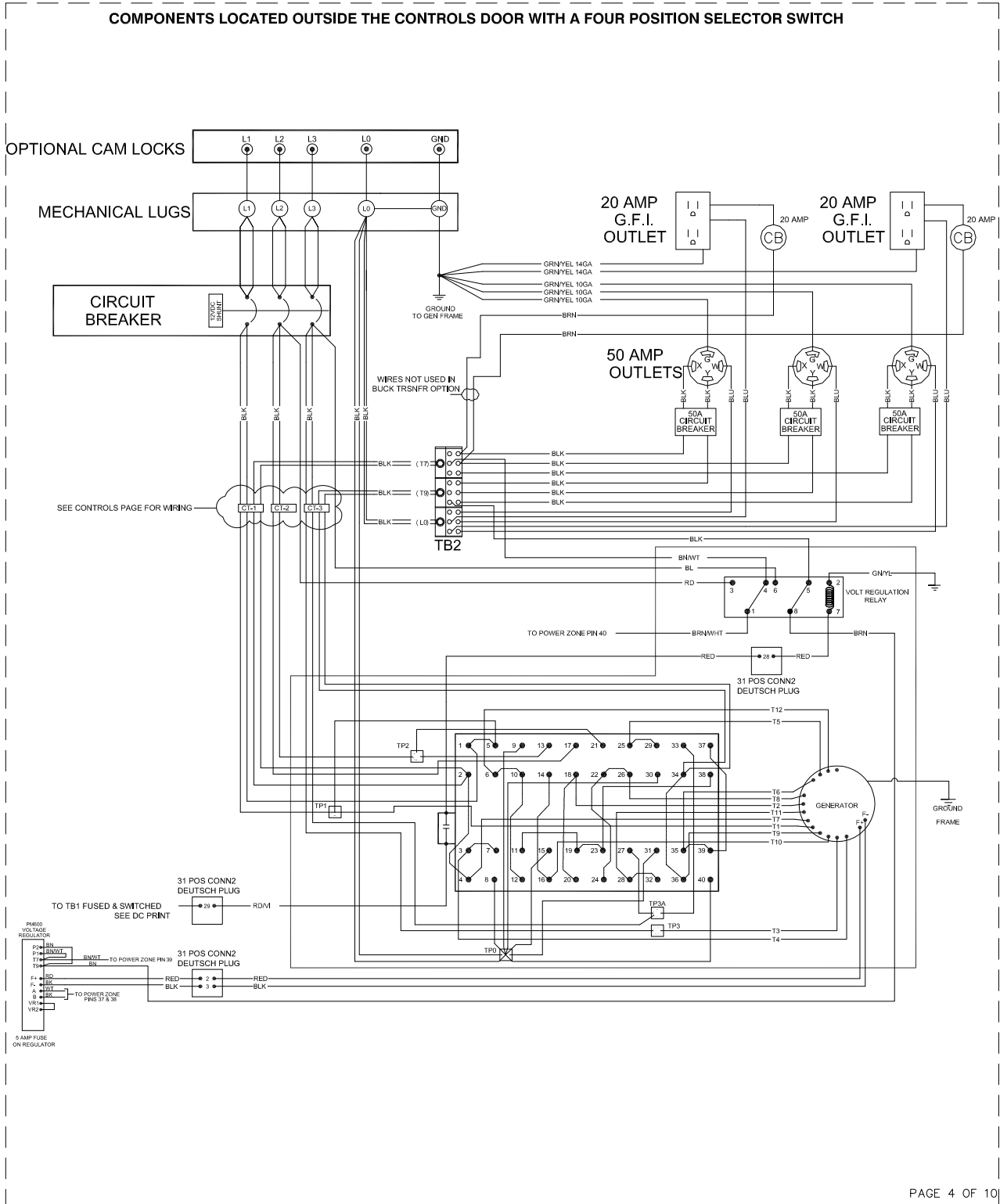

GROUP G

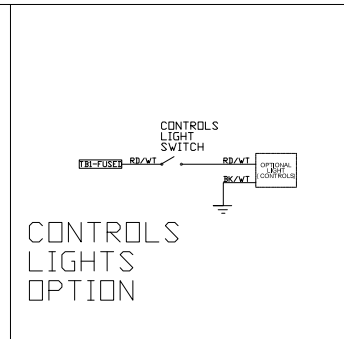
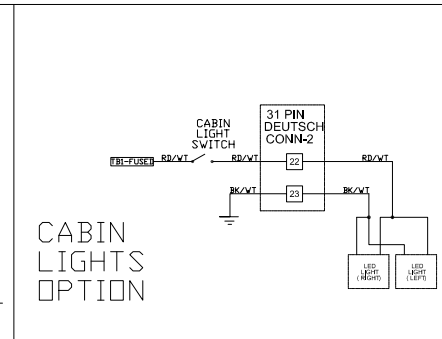
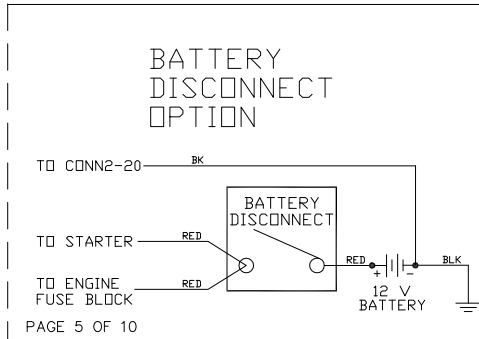
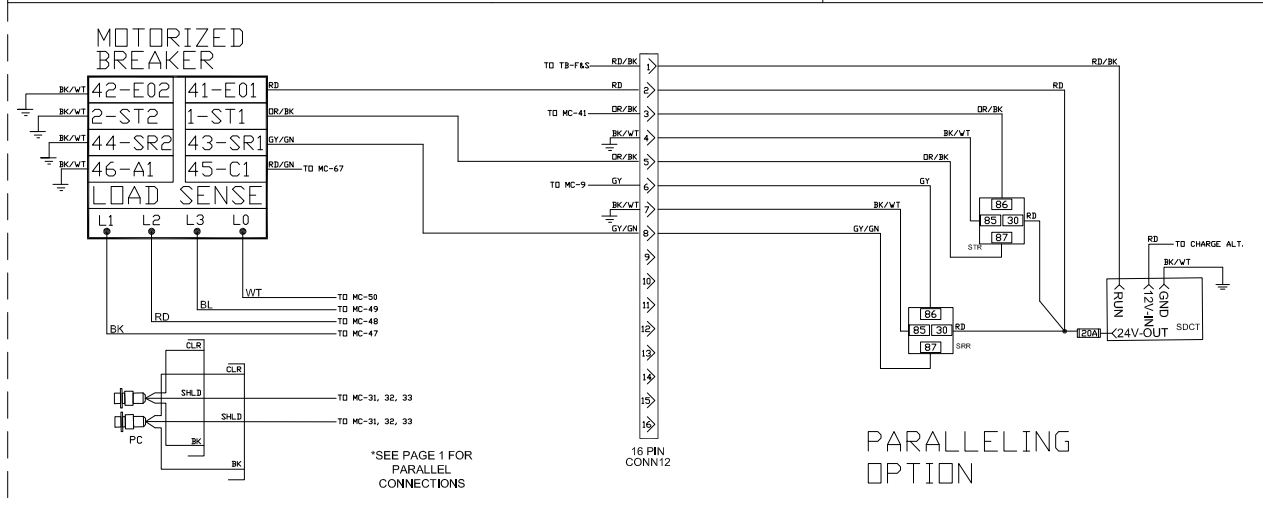
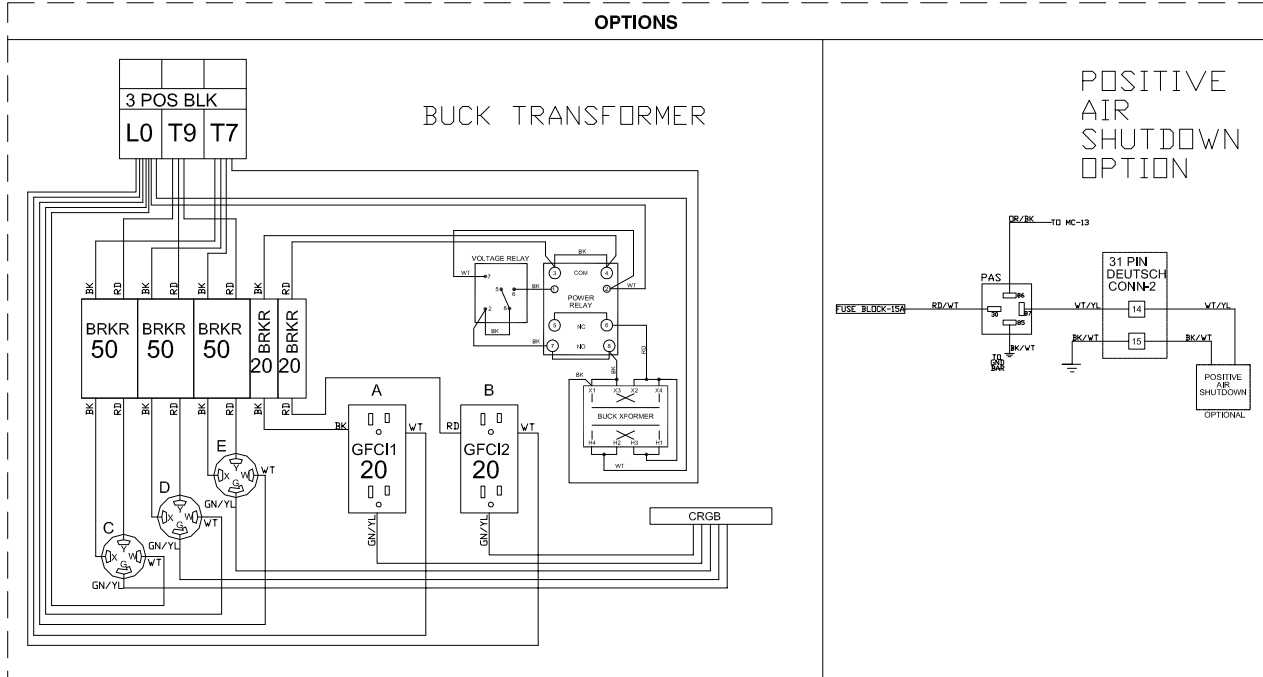

REVISION: C
DATE: 7/5/17

PAGE 5 OF 10

WIRING - DIAGRAM
MDG100/75 DF4
DRAWING #: 1000020202

GROUP G

VOLTAGE REGULATION AND PMG COMBINED OPTIONS

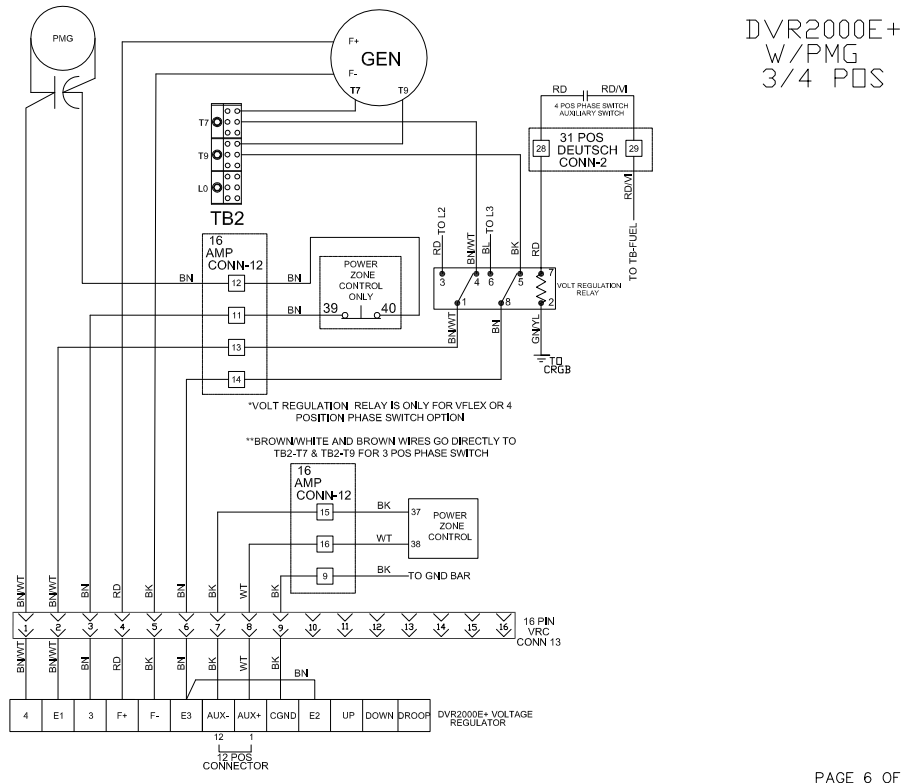
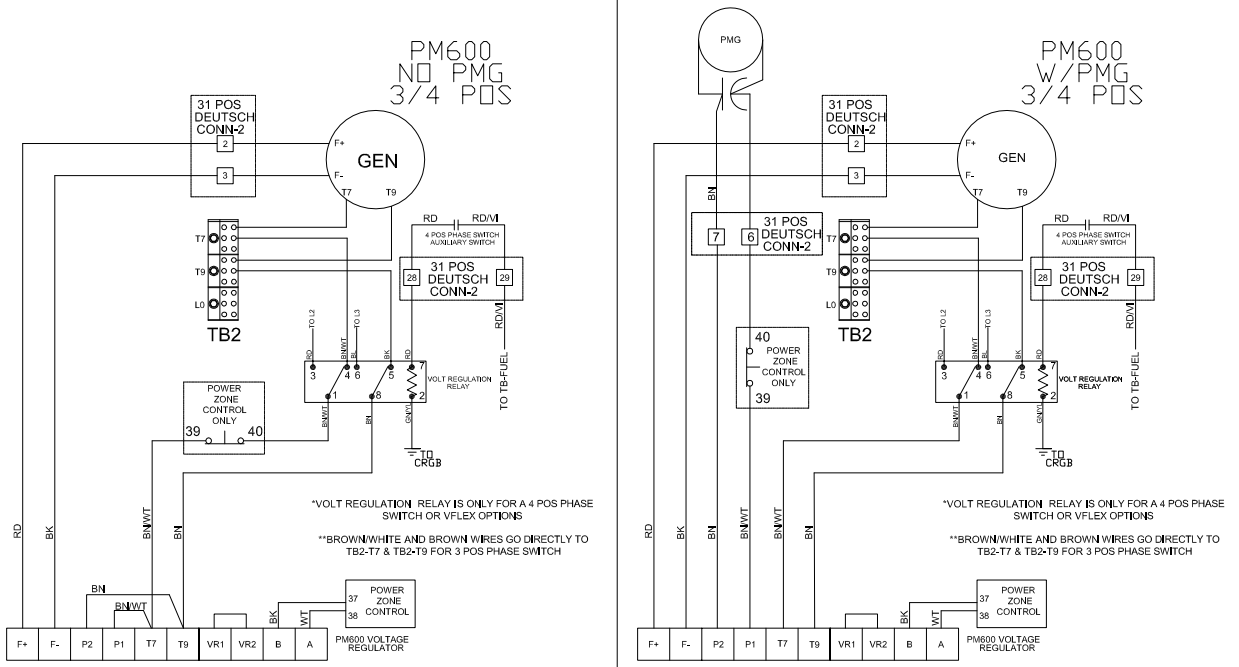

GROUP G

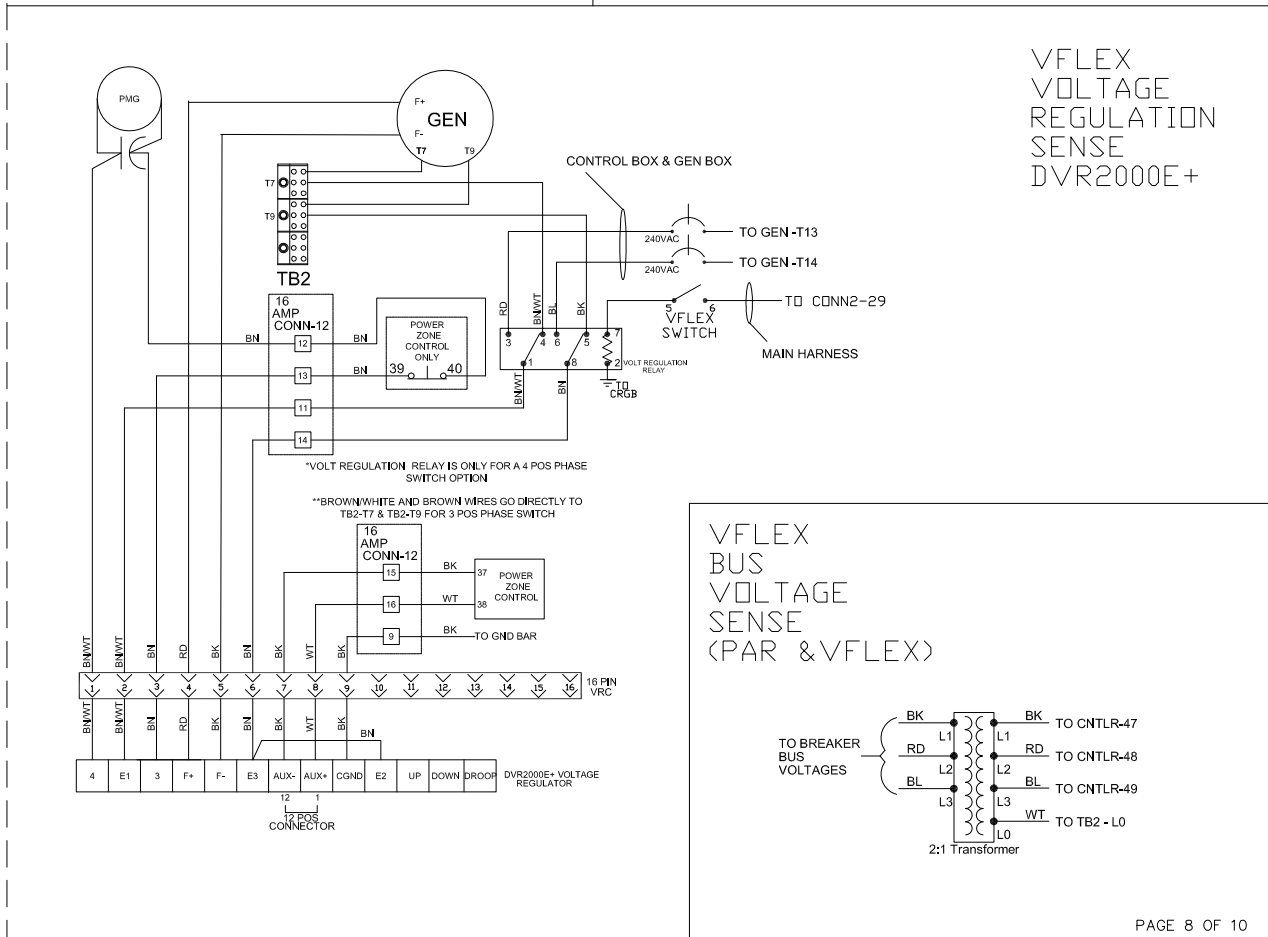
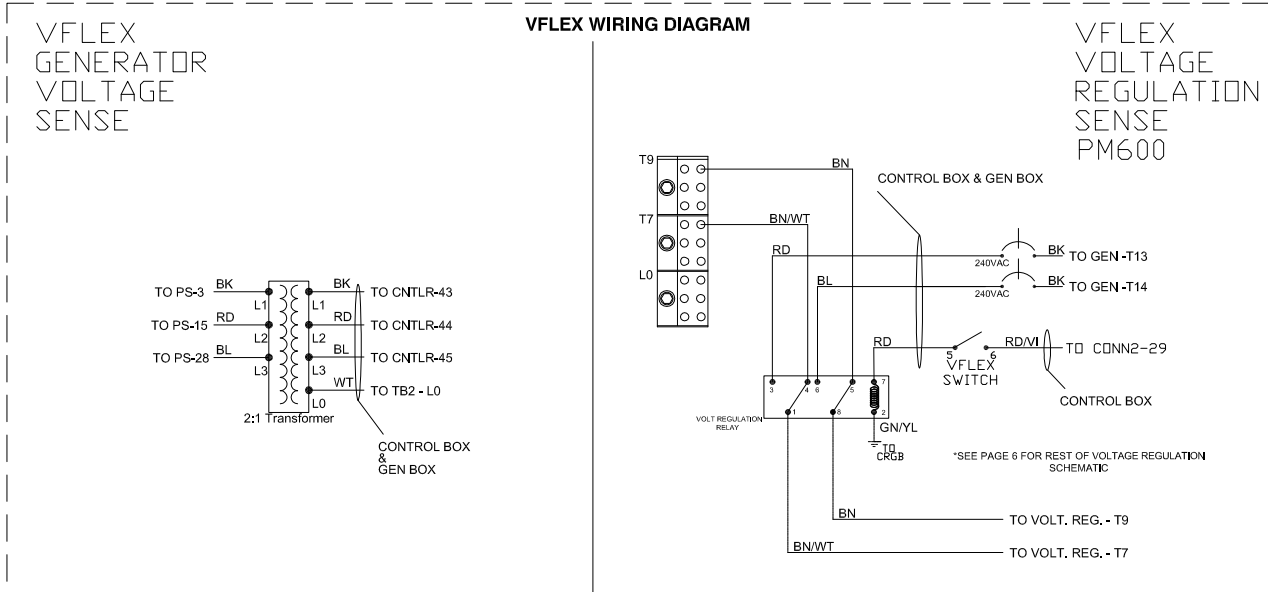

REVISION: C
DATE: 7/5/17

WIRING - DIAGRAM
MDG100/75 DF4
DRAWING #: 1000020202

GROUP G

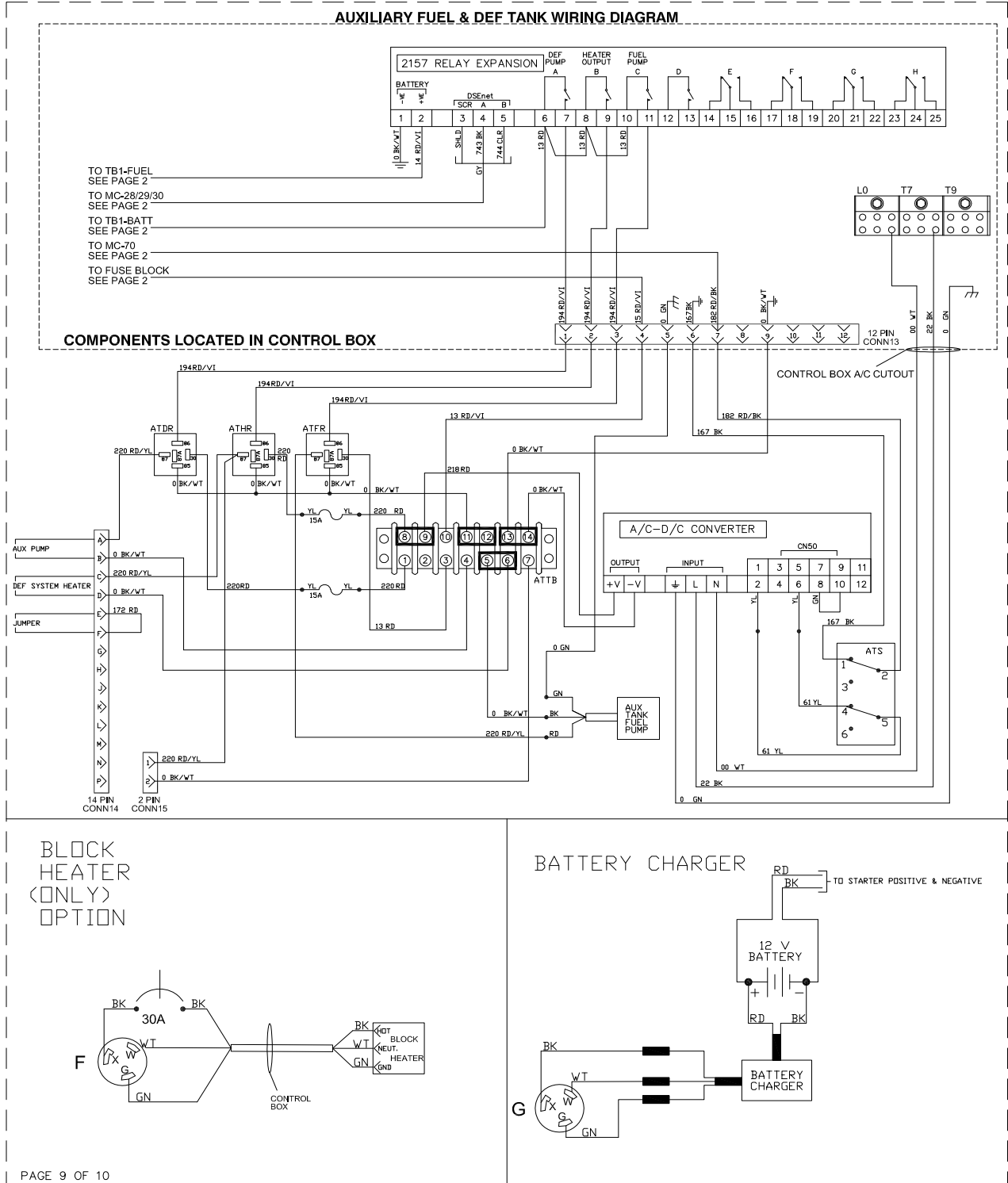

PAGE 9 OF 10

REVISION: C
DATE: 7/5/17

PAGE 9 OF 10

WIRING - DIAGRAM
MDG100/75 DF4
DRAWING #: 1000002020

GROUP G

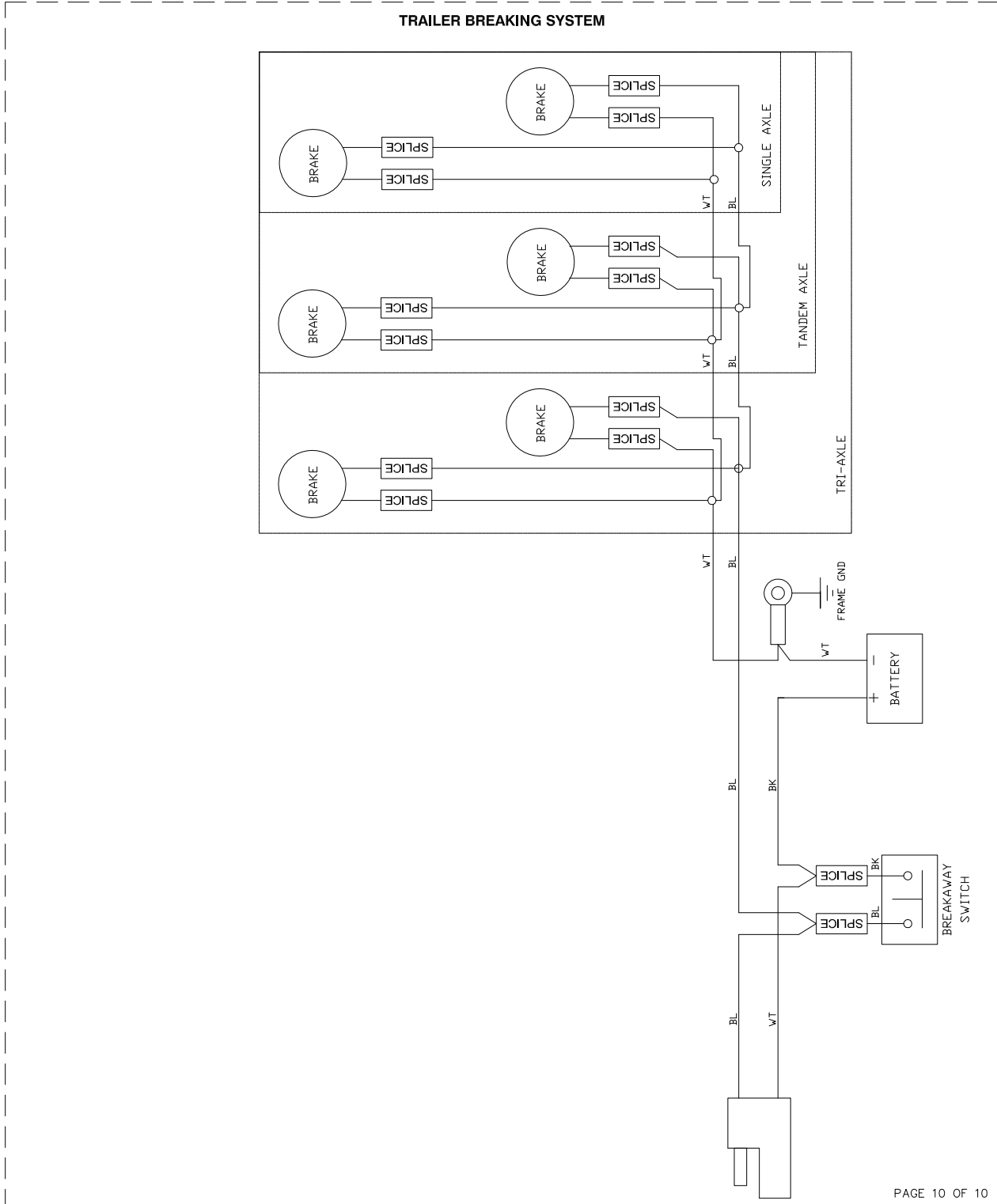

PAGE 10 OF 10

WIRING - DIAGRAM

MDG100/75 DF4

DRAWING #: 10000020202

REVISION: C
DATE: 7/5/17

PAGE 10 OF 10

This page intentionally left blank.

This page intentionally left blank.

Part No. A0000393907 Rev. A 2/28/2020

©2020 Generac Mobile Products, LLC
All rights reserved.
Specifications are subject to change without notice.
No reproduction allowed in any form without prior written
consent from Generac Mobile Products, LLC.



Generac Mobile Products, LLC
215 Power Drive, Berlin, WI 54923
GeneracMobileProducts.com | 800-926-9768 | 920-361-4442